

Apollo Sales Corp.

P.O. BOX 248

OSCEOLA, IN 46561



PROSPECTING

MINERAL AND METAL DETECTORS
TREASURE HUNTING

COIN SHOOTING

A P O L L O 2

(Ten Turn Tuner)

Instruction Manual

FEATURES

- * Metal/Mineral Tuning - Allows you to discriminate between ferrous and non-ferrous metals.
- * Fully Transistorized - Up to date solid-state electronics.
- * Battery Check Circuit - Allows you to test your batteries at anytime without having to take them out of your instrument.
- * Volume Control - Adjusts the loudness of the tone in the speaker, and in the headphones (when headphones are used).
- * Meter - Provides an indication when an object is detected, and is especially helpful in noisy areas.
- * Wink Light - Provides an additional indication of a find, and also is helpful in noisy areas.

ASSEMBLY INSTRUCTIONS

After unpacking the instrument, you will find the instrument rod. This rod has two snap locks, one is for mounting the rod to the instrument by depressing the two pins and then sliding the rod into the rod sleeve (on the bottom of the instrument) until it snaps into place. The other snap lock is for adjusting the rod to the desired length. This is done by depressing the two pins and then pulling the small section of the rod out of the large section until the snap pins reach the next position, then allow the pins to snap into place. If the small section is rotated slightly, the next position may be by-passed.

To mount the loop proceed as follows: If the loop is the non-adjustable angle loop, merely insert the loop bolts into the two holes on the free end of the rod and install the thumb nuts finger tight.

If you are mounting the adjustable angle loop, place the loop on the free end of the small rod and secure with the single screw provided. Tightening this screw determines the freedom of the loop to change angles. The screw should be tightened so that the loop can be changed in angle, yet hold the desired position.

After mounting either loop, next spiral the loop cable around the rod, and plug the loop cable into the socket on the front end of the instrument. The plug and socket are keyed to allow mating with only the correct pin alignment.

BATTERY INSTALLATION

To gain access to the battery compartment, release the latches on the sides and pull back and down on the upper part of the hinged door. Remove the tape from the battery leads. You will note that one battery connector is white and the other black. The white connector should be connected to the white holder and the black connector to the black holder.

CAUTION: Observe polarity when connecting.

BATTERY TESTING

Before using your instrument, you should check your batteries by placing the POWER SWITCH in the 9 & 12 positions and notice the readings. Good batteries will read in the bracket marked BAT CHECK on the meter. When the reading falls below this bracket the batteries in the pack should be replaced. The white holder is the 12 volt battery and the black holder is the 9 volt battery.

Generally the batteries in a pack will all decrease at the same rate. However, if you suspect a single defective cell, you can check each cell individually by placing the power switch in the OFF - ONE CELL position and inserting each battery into the single cell holder (observing polarity) and noticing the reading. Again the reading should be inside the BAT CHECK bracket.

Any AA penlight battery may be used as a replacement, however we recommend Ray-O-Vac. If you would like to use rechargeable penlights, be sure they are 1.5 volts and not 1.2 volts.

USE OF CONTROLS

1. METAL / MINERAL CONTROL: The Metal-0-Mineral Control adjusts the level of sensitivity as well as selecting Metal or Mineral. Very slowly rotate this control counter-clockwise (LEFT) for a metal setting. Note there will be a point where you hear a small weak tone. This point we will call the threshold point or level. The threshold level is the best setting for maximum effective sensitivity. The meter reading should be a little below zero at the threshold point. It is impractical to attempt to maintain the meter at any exact setting, because all normal movements in the field affect meter readings to some degree depending on the amount of mineral in the area you are working.

For effective results, these adjustments must be made with the instrument in hunting position, (see Figure B, under Operating Illustrations), holding the loop as close to the surface of the area to be explored as is practical for movement of the loop. You are now adjusted for detecting metal.

Mineral settings are made by rotating the Metal-0-Mineral control clockwise (RIGHT) to the threshold point which will occur the same as when tuning for metal, but now your responses will indicate mineral. The other controls function the same for both mineral and metal. (See false readings under interpretation of signals, if you feel your instrument responds to both metal and mineral on the same setting.) You are now adjusted for detecting minerals.

2. VOLUME CONTROL: This control adjusts the loudness of the tone in the speaker as well as in the headphones if they are used. Whenever headphones or earphones are plugged in, the speaker becomes disconnected. Turning the volume control to the RIGHT increases the loudness while to the LEFT decreases the loudness. Before using headphones, turn the volume control all the way to the LEFT, and then gradually increase it until the desired level is reached.
3. POWER SWITCH: When not checking batteries, the power switch should be in the ON position. In this position the meter functions as an INTENSITY METER.

OPERATING PROCEDURE AND TECHNIQUES

To operate the instrument proceed as follows: METAL / MINERAL CONTROL in the middle or null (quiet) position. VOLUME CONTROL should be turned fully clockwise. POWER SWITCH IN THE ON position. If you wish to use the WINK LIGHT, turn the wink light power switch to ON (the red toggle switch located in the lower right hand corner of the front panel of the detector.)

To search for non-ferrous metals, such as coins, rings, silver, gold, copper, tin cans, bottle caps, tin foil etc., turn the Metal / Mineral knob to the LEFT until you hear a small tone. Next lower the loop towards the ground. If the tone goes quiet as the loop gets close to the ground, then you are in an area that has MINERALIZED soil and this means you will have to re-adjust the METAL / MINERAL TUNER more towards METAL until you once again hear a tone. This also means that it will be harder to operate the detector due to this MINERALIZATION, because once you have re-adjusted the tuner if you raise the loop even a small amount, it will cause the detector to get louder. Therefore the more mineralized the soil, the more difficult it is to detect objects, while the less mineralized the soil, the easier it is.

Now while holding the loop as close to the ground as possible, slowly sweep the loop across the ground (being very careful not to raise or tilt the loop), making an arc or sweep that covers about 6 feet then move the loop forward about 3 inches and make another sweep. If using in short grass, such as a lawn or park it is possible to place the loop on the grass, and slide it on the top. This helps keep the loop at a constant height and helps to maintain a sensitive tuning adjustment which is necessary to locate the deeper or harder to get objects. For large objects, the tuning is not as critical and the loop can be held above the surface. To practice, bury a quarter approximately one inch deep in your yard and practice on it until you get used to the type of sound it makes when you pass over it. Also you might change the tuning slightly on the tuner and notice how the indication changes. When using your detector it is a good policy to re-adjust your tuner every 5 to 10 minutes to maintain the highest sensitivity setting.

Also the longer an object has been in the ground the easier and deeper it can be detected. This is because as the object stays in the ground it causes the ground around it to become conductive and the longer its been in the ground the more ground around the object has become conductive and the bigger the object looks to the detector. Generally speaking the bigger the object, the deeper it can be detected.

To search for ferrous metals and/or mineralized veins, such as found around gold deposits, turn the METAL / MINERAL TUNER to the RIGHT towards MINERAL until a tone is heard. Then lower the loop to the ground. Again if the ground contains mineralization you may once again have to re-adjust, except this time it will be because the detector got louder instead of quieter. Now sweep the loop across the ground as you did for the METAL setting, only this time if you hear a loud tone it will be because you found either a ferrous object, such as iron or steel or you have found black sand or some other strong mineralized location.

METER, SPEAKER AND WINK LIGHT

Whenever you detect an object you will hear a loudness change in the speaker and you will see a deflection on the meter, and if you are using the WINK LIGHT, you will see a brighter glow on the light bulb. These strong readings can be maintained as long as the loop is held directly over the object. As you move away from the object, the sound will decrease, the meter will return to zero and the wink light (if used) will dim.

CARE OF INSTRUMENT

WHEN USING YOUR INSTRUMENT IN SALT AIR, care should be used to prevent rust. Coat all exposed screws and bolts with Vaseline before using, and when through wipe the entire detector with a lint free cloth to remove dirt and moisture.

Do not use the instrument in excessively hot or cold temperatures, or store it in excessively hot or cold places.

If the instrument is to be laid away for any great length of time, the battery packs should be removed and the batteries removed from the holders. Then store the batteries in a dry, cool place, such as on a shelf in a closet. This is to prevent the batteries from damaging either the instrument or the holders if one or more of the batteries leak.

SERVICE PROCEDURES

The instrument has a full two (2) year warranty on all parts (except batteries) and labor. If ever in need of service, please contact the place of purchase and they will either be able to service your detector or they will advise you where to send it for repairs. Also the service centers on the enclosed list have been authorized to service the instruments.

APOLLO SALES CORPORATION
Post Office Box 248
Osceola, Indiana 46561

BATTERY DIAGRAM

Note: To prevent damage in shipping, the batteries have been removed from your instrument and placed in a separate container within the shipping carton. See following diagram for proper installation.

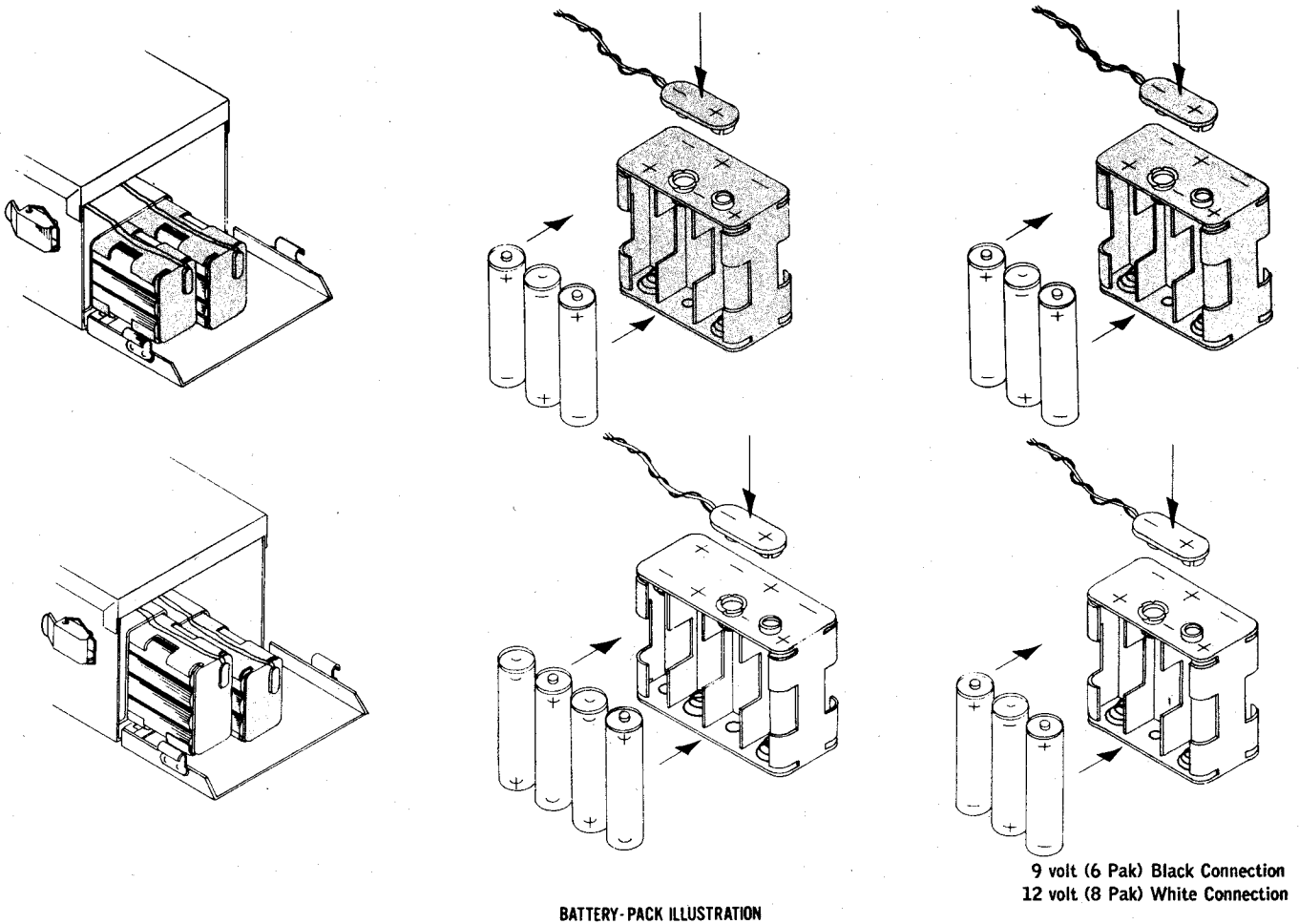

BATTERY-PACK ILLUSTRATION

9 volt (6 Pak) Black Connection
12 volt (8 Pak) White Connection

1.5 Volt "AA" (Battery Pack Models)

EVEREADY

1015

BURGESS

910

When ordering replacement batteries from the factory, please state the instrument model, voltage of batteries and battery number.

ROD ASSEMBLY, DRAWINGS

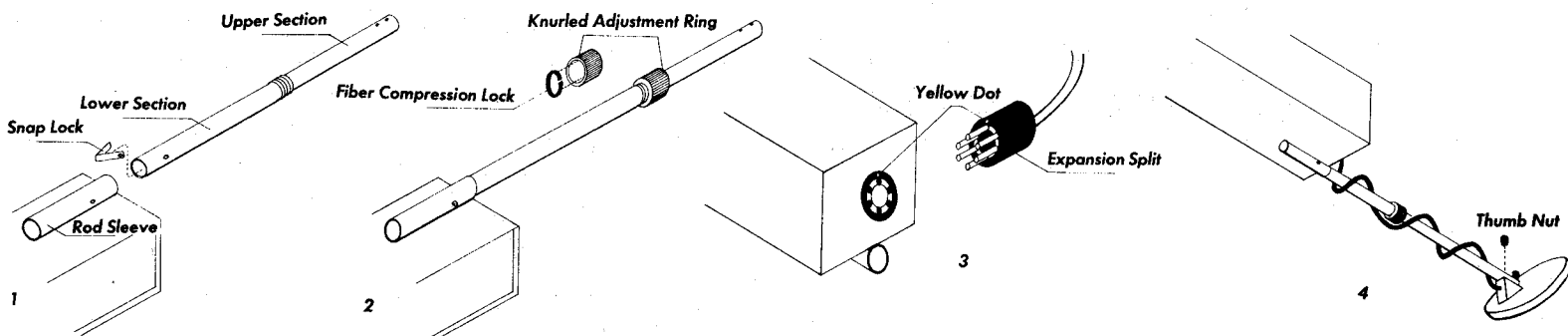

When you receive your instrument with the knurled adjustment rod, it may be necessary to install the snap lock. As illustrated in Figure Number 1. Depress snap lock and insert it in the lower section. Insert the lower section into the rod sleeve.

Figure Number 2 shows the fiber compression lock; make sure it is inside the knurled adjustment ring. Slip the ring over the upper section; adjust rod to desired length and tighten ring as shown.

When attaching the loop cable to the instrument chassis, make sure the yellow dot on the plug matches the one on the instrument. As shown in Figure Number 3 (note: the "Expansion Split", as pictured in Figure Number 3, is to allow assembly and disassembly of the plug cap and is not a manufacturer's defect).

Attach the loop with the thumb nuts as shown in Figure Number 4. Always coil the loop cable as snugly as possible, without pulling or stretching it.

OPERATING ILLUSTRATIONS

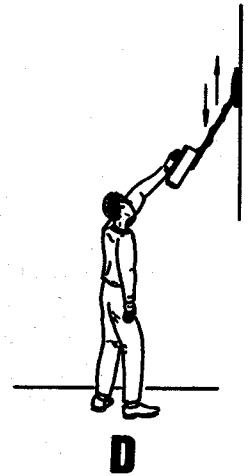
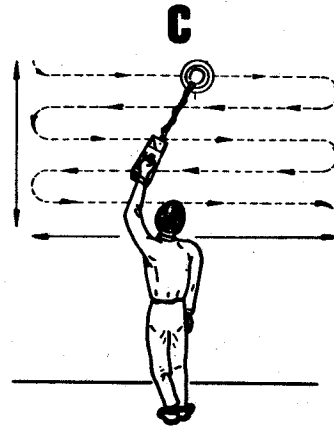
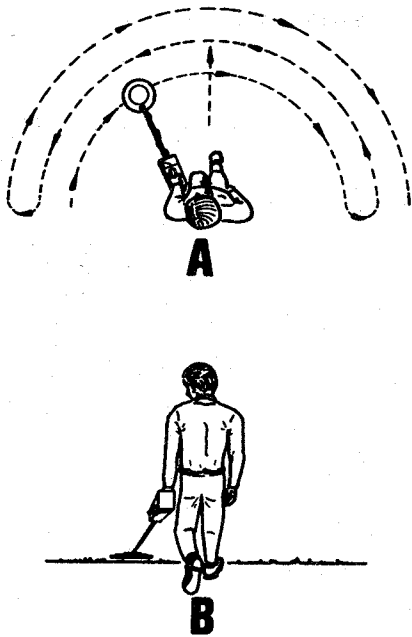

As shown in Diagrams A and B, when you are working on the ground, move forward in a straight line, at the same time, moving the loop from side to side across in front of you. The distance between each swath of the loop is determined by the size of the loop you are using. With a 6" loop you would make a 3" step, with 12" loop you would make a 6" step, and so on. Using this method of hunting enables the hunter to cover more ground, more completely, in less time. For tuning your loop, hold it as close to the ground as possible.

Diagrams C and D show you just one more of the many ways the versatile design of the instrument can help you either in prospecting or treasure hunting. This diagram demonstrates the extra ability the design gives in reaching to the out-of-the-way places. This system can be used for checking outcroppings, walls, etc.

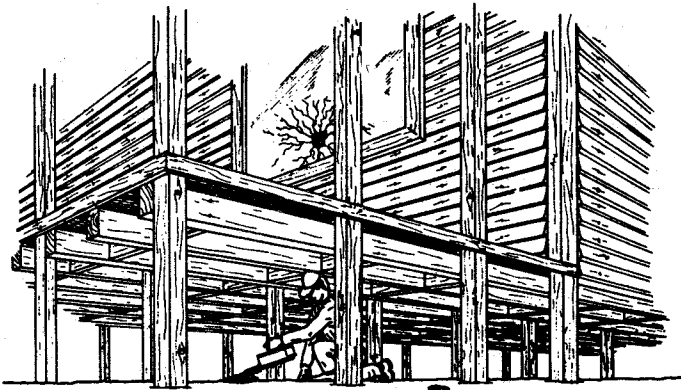

Remember, a lot of old artifacts and treasure have been found under old buildings, as well as in the attics. When going through an old homestead, never overlook any place or area that could represent a good hiding place. So if you are planning such a trip, follow these simple illustrations and prepare your instrument. At a time like this you don't want to pass up any chances.



Apollo
Sales Corp. • P. O. Box 248 • Osceola, In. 46561

SOLD EXCLUSIVELY IN THIS AREA BY

PRINTED IN U.S.A.

 Apollo