

Apollo Sales Corp.

P.O. BOX 248

OSCEOLA, IN 46561



PROSPECTING

MINERAL AND METAL DETECTORS
TREASURE HUNTING

COIN SHOOTING

OPERATING INSTRUCTIONS
FOR
A P O L L O M O D E L 20

Please follow these instructions carefully, to operate the instrument correctly. Please practice with the instrument at every opportunity.

INTRODUCTION

We do not believe that you can buy a finer instrument than you have chosen for the use that the instrument is designed for, but remember that the instrument is no better than its operator, (even though we have heard customers say that the instrument was smarter than they.) You are the operator, and the more familiar you become, through use and practice the better operator you will be. The better the operator, the more finds you will make.

GENERAL DESCRIPTION

These instruments are completely transistorized (solid state), giving maximum sensitivity, excellent reliability, and economy in operation. They are designed specifically for coin hunting, but have features which allow them to be used for general exploration.

The audio system is complete, offering both earphone and speaker operation.

These instruments employ the balanced induction principle of operation, the loop being the heart of this system.

These instruments have a sensitive meter giving good reaction on finds as well as testing the batteries.

Batteries used are penlight, size "AA" 1 1/2 volt cells. Six are required for operation. Six cells in a holder, yielding 9 volts.

The Single Tuning Control incorporates a power switch, as well as controls the tuning of the instrument for the easiest and simplest operation.

ROD AND LOOP ASSEMBLY:

After unpacking your instrument, check the tightness of the screw for the adjustable loop. Tightening this screw limits the ability of the loop to change position in relation to the rod. The loop should be adjustable to different angles, and yet hold desired position. Mount the loop at half way adjustment point (90° to the rod) during assembly.

Next, align the rod sections and mate by depressing the spring clip and inserting the rod into the larger rod section until the first pair of matching holes align. It may be necessary to feed extra cable length from the end of the rod (near loop) by hand as the rod sections go together. It will also be necessary to remove excess cable length from rod if it is desired to shorten the rod length to the next pair of matching holes. A small loop in the cable could be formed where it exits the rod.

VOLUME CONTROL

The volume control adjusts the loudness of both the speaker and the earphones or headphones, therefore when using earphones or headphones, be sure to lower the volume control to minimum, and then gradually increase it until you have the desired volume level. Turning the volume control to the right (clockwise) increases the volume or loudness, while to the left (counter-clockwise) lowers or decreases the volume.

LAMP USAGE

When an object is detected, the signal is sent to either the speaker or the lamp. The brightest reading on the lamp or loudest volume in the speaker is when the loop is directly over the object.

To use the lamp proceed as follows:

Turn the Volume Control to the extreme left until a click is heard.

The lamp can now be used instead of the speaker to indicate a find.

METAL SETTING

The Metal Control adjusts the level of sensitivity as well as controlling the Power Switch. Very slowly rotate this control Clockwise, (Right) and you will hear a distinct "Click". This is the Power Switch energizing the circuit. Continue to turn this Control until a tone is heard in the speaker, (when making these adjustments, hold the loop approximately 1 inch above and parallel (flat) with the ground and do not raise or lower the loop excessively while doing so.)

There may be a sudden loud tone sound, just as soon as the switch clicks on, for a few seconds duration. If so, this is normal- as soon as the tone stops - then continue to turn the control to the right, until the tone again just starts to come in. The instrument is now ready for operation.

HUNTING METHODS AND TECHNIQUES

When passing the loop over a non-magnetic conductive metal, such as the metal sample you received with your instrument, the sound will increase in the speaker and will be retained as long as the loop is held over the metal object. As soon as the loop passes away from the metal object, the sound will lower in volume to approximately the same as before the object was detected.

Earphone usage: To use the earphone install its plug into the jack on the instrument. Note this cuts off the speaker giving privacy in listening. You may use the earphone whenever you wish, its special feature being that of giving you a concentrated tone close to your ear, which excludes interfering noises about you.

The small deeper coins, at times give just a slight tone change, due to their depth. In these cases, the phones are the most effective method of detection.

Tin cans, bottle caps, tin foil, aluminum foil, cartridge cases, coins, silver gold, copper, lead and brass are some of the highly conductive metals that will cause a response in the speaker or earphones.

The instrument is not designed to react to sticks, rags, bones, paper or any other non metallic objects.

When looking for small metal objects, such as coins, the ability of the instrument to detect them will vary in different areas. The more mineralized the soil, the more difficult it is to detect them, and the less mineralized, the easier. Also the longer the metal object has been buried, usually the easier and deeper it may be detected, as the ground becomes electrically conductive from the metal object over a period of time. In some cases you may detect a very old tin can and after digging it up, still receive a reading over the spot the can was buried in.

To locate hidden or buried metal objects, slowly and systematically sweep the loop across the area to be checked, (See Figure A) being very careful to hold the instrument so that the loop is held at as constant and uniform height as possible with the least up and down variation in relation to the formation or ground you are using the instrument over. When searching for small objects, such as a single coin, the instrument should be tuned in with the loop held as close to the ground as possible. Hold this height as close as you possibly can, and search the ground carefully, usually on the surface, if possible, depending on the surface you are using the instrument over. If the ground is rough, you may have to zero the instrument in higher. For larger objects, one can hold the instrument approximately 1 to 2 inches above the surface to be explored. Keep repeating this process until you have explored the entire area. With each sweep of the instrument you will cover approximately 6 feet by 3 inches. If there is anything under the surface, and it is within detectable range of the instrument, you should be able to find it.

In the short green grass, such as a lawn, it is possible to place the loop on the grass, tune it in, and slide the loop over the grass to locate the smaller objects. The loop automatically is kept at the same height by the grass, so a uniform and more constant tone may be maintained, which is important for the very small objects. For large objects, the instrument may be carried at a higher elevation and it is not so critical to height variation and will respond to the larger metal object. To practice, lay some metal objects on a wood floor or on your lawn and move the loop over them, and notice the way the instrument responds.

It is a good policy to slightly adjust the Tuning Control every 5 to 10 minutes to keep the instrument at its highest peak of sensitivity, when searching for small objects, such as single coins, along beaches, etc., and every 10 to 15 minutes or so for larger objects.

A NOTE ON HEADPHONES:

Greatest sensitivity or penetration is realized when using headphones. You cannot detect well when you cannot hear the audio changes properly. Headphones concentrate the sound and reveal faint audio changes that couldnot be heard without them. Also, many people have hearing problems that headphones help overcome. They are worth the extra money.

BATTERIES:

To gain access to the battery compartment, hold the instrument as shown in the picture. Place your thumb or fingertips on the rear compartment door labeled, "PRESS". Press inward, to unlatch the lock and then slide the door down. The door will then be open to allow removal of the battery pack.

Be sure, when replacing batteries in battery holder, to maintain proper battery polarity. If your instrument does not operate after installing new batteries, check each battery polarity carefully. For prolonged periods of detector storage (several weeks or longer), it would be wise to store the battery pack in your refrigerator. Also, it is wise to have an extra battery pack or extra batteries along on outings.

CAUTION:

The instrument should never be left where the sun, on a hot day, will overheat the instrument. It is best to lay it in the shade when not in use. Excessive heat can damage some of the sensitive electronic parts and the batteries. If the instrument is left in a car on a hot day, it should be covered by a blanket or some other covering to protect it from the direct sun rays and the windows cracked to permit ventilation.

SERVICE - WARRANTY - REPLACEMENT BATTERIES

This model contains one battery holder containing 6 AA Batteries. You may order new replacement batteries directly from our plant, if you cannot find them locally or at your dealers.

The new penlight battery system is better in many respects to the old type batteries:

1. Longer life
2. Readily available
3. Superior performance
4. Cheaper in replacement. (If one cell fails, you only need to replace the one cell.)

Replacements: Any AA penlight batteries.

Alkaline energizers and batteries of this type may be used and give even longer life.

Note: All batteries last longer if used in many short periods, rather than in a couple of long periods of use.

Operating Instructions
Apollo Model 20

-5-

When through operating the instrument, turn the Power Switch-Tuner Control to the "Off" position.

Care should also be taken in excessively cold weather to protect the instrument, as well as the batteries from freezing.

If the instrument is to be laid away for any great length of time, the battery pack should be un-snapped and the pack removed from the instrument. This will prevent damage to the instrument in case one or more of the batteries are damaged or in case the power switch is left on or gets turned on accidentally. The damage to the instrument in this case is similar to what occurs in a flashlight, when the battery is discharged and the liquid escapes to damage the case and components.

The instrument has a two (2) year warranty on parts and labor (except on batteries) to the original purchaser, from the date of sale, with a \$2.50 handling charge on all instruments returned for service.

If ever in need of service, ship the instrument by insured parcel post, freight or stage, prepaid and enclose a letter advising the nature of your troubles. It must be returned to the address listed below.

APOLLO SALES
P.O. Box 248
Osceola IN 46561

Printed in U.S.A.

BATTERY COMPARTMENT

Note:

TO PREVENT DAMAGE IN SHIPPING, the batteries have been removed from your instrument and placed in a separate container within the shipping carton. See following diagram for proper installation.

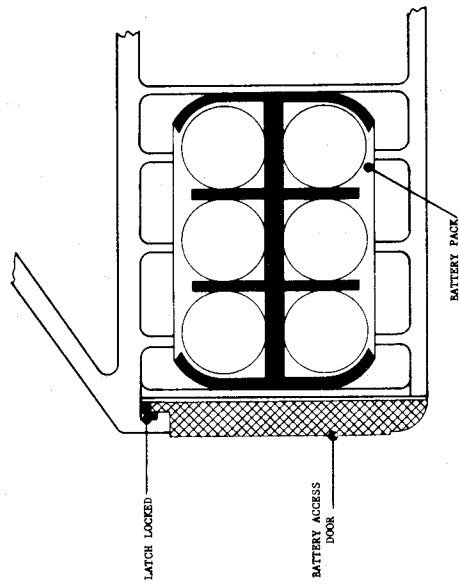

Fig. 1

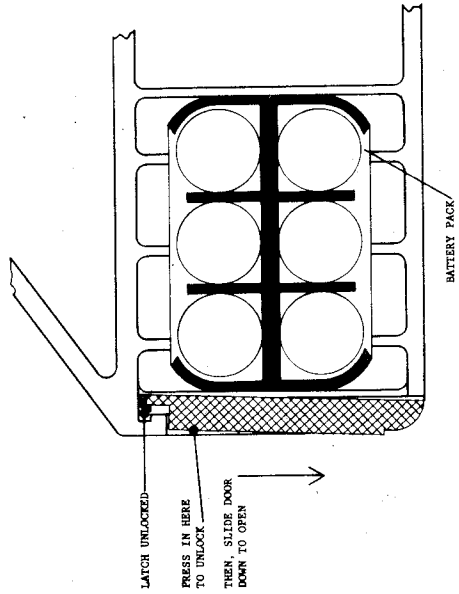

Fig. 2

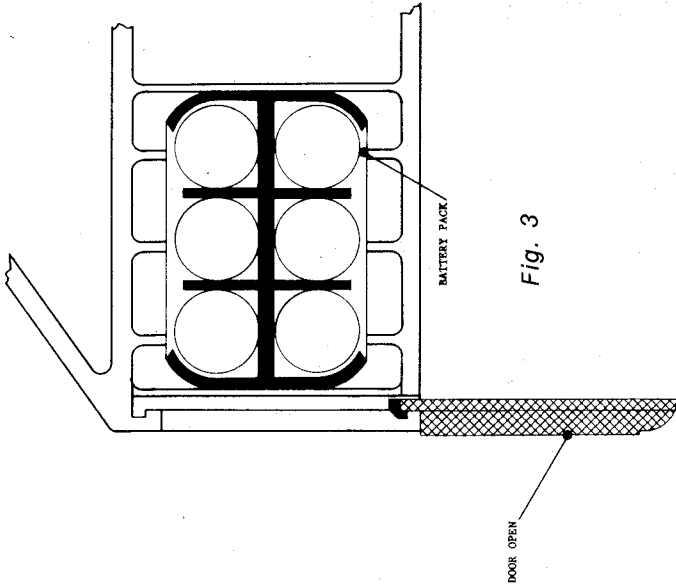
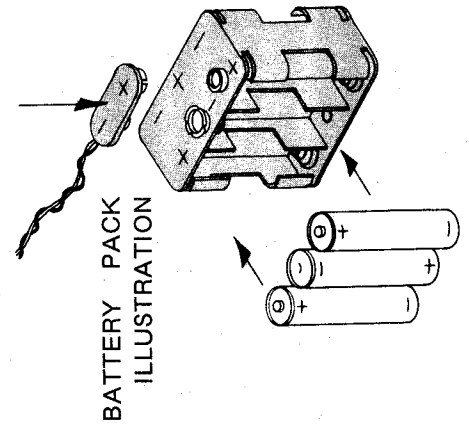
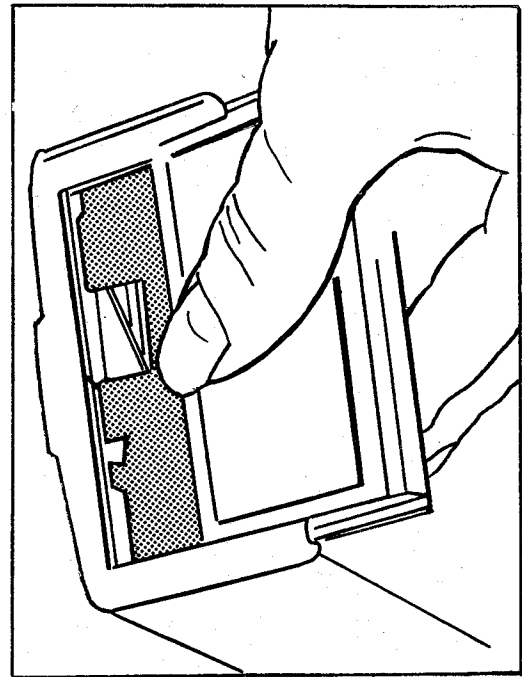

Fig. 3



1.5 Volt "AA"
(Battery Pack Models)
RAY-O-VAC #15

When ordering replacement batteries from the factory, please state the instrument model, voltage of batteries and battery number.

OPERATING ILLUSTRATIONS

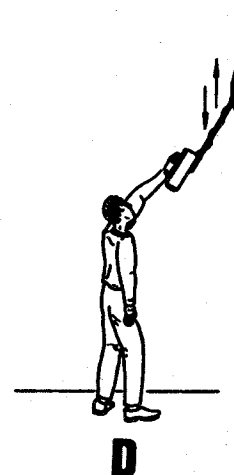
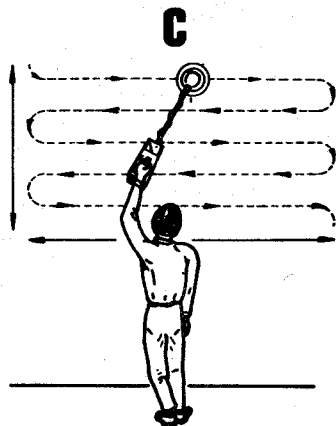
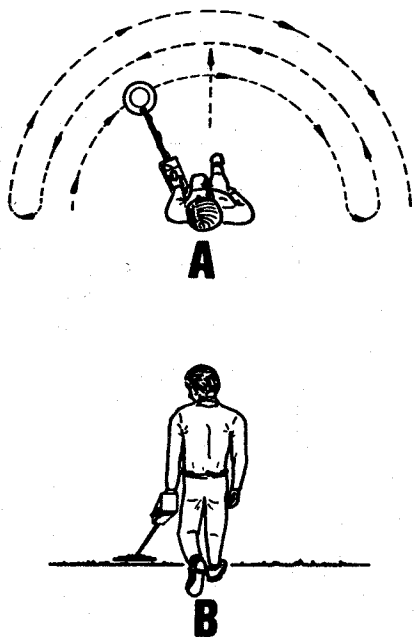

As shown in Diagrams A and B, when you are working on the ground, move forward in a straight line, at the same time, moving the loop from side to side across in front of you. The distance between each swath of the loop is determined by the size of the loop you are using. With a 6" loop you would make a 3" step, with 12" loop you would make a 6" step, and so on. Using this method of hunting enables the hunter to cover more ground, more completely, in less time. For tuning your loop, hold it as close to the ground as possible.

Diagrams C and D show you just one more of the many ways the versatile design of the instrument can help you either in prospecting or treasure hunting. This diagram demonstrates the extra ability the design gives in reaching to the out-of-the-way places. This system can be used for checking outcroppings, walls, etc.

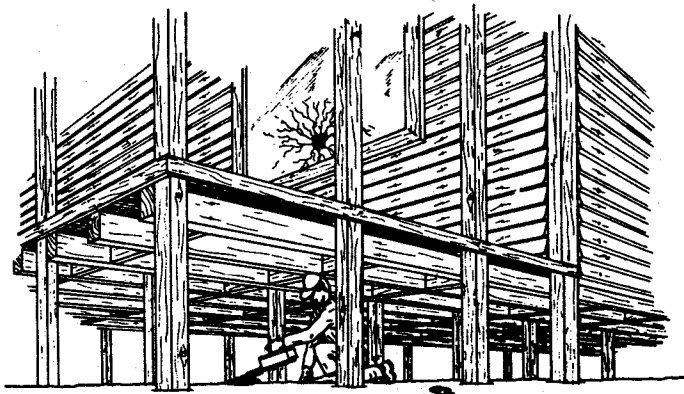

Remember, a lot of old artifacts and treasure have been found under old buildings, as well as in the attics. When going through an old homestead, never overlook any place or area that could represent a good hiding place. So if you are planning such a trip, follow these simple illustrations and prepare your instrument. At a time like this you don't want to pass up any chances.



SOLD EXCLUSIVELY IN THIS AREA BY

Sales Corp. • P. O. Box 248 • Osceola, In. 46561

PRINTED IN U.S.A.



Appollo