

White's Electronics, Inc.

1011 PLEASANT VALLEY ROAD

SWEET HOME, OREGON 97386

OPERATORS INSTRUCTIONS



Manufacturers of The World's Largest Line of Mineral and Metal Detectors

MINERAL AND METAL
DETECTORS

ELECTRONIC
MAGNETOMETERS

SUPER GEIGER AND
SCINTILLATION COUNTERS

ULTRA VIOLET
LIGHTS

OPERATING INSTRUCTIONS
for
GOLDMASTER MODEL 63TR

Please follow these instructions carefully, to operate the instrument correctly and practice with it at every opportunity.

INTRODUCTION

We do not believe that you can buy a finer instrument than you have chosen for the use that the instrument is designed for, but remember that the instrument is no better than its operator, (even though we have heard customers say that the instrument was smarter than they.) You are the operator, and the more familiar you become, through use and practice the better operator you will be. The better the operator, the more finds you will make.

GENERAL DESCRIPTION

These instruments are completely transistorized (solid state), giving maximum sensitivity, excellent reliability, and economy in operation. They are designed specifically for coin hunting, but have features which allow them to be used for general exploration, and even prospecting on a limited basis.

The audio system is complete, offering both earphone and speaker operation, controlled by a common volume control.

These instruments have a sensitive meter giving good reactions on finds, as well as testing both battery systems under operating conditions.

These instruments employ the balanced induction principle of operation, the loop being the heart of this system.

Batteries used are penlight, size "AA" 1 1/2 volt cells. Fourteen are required for operation. Six cells in a holder, yielding 9 volts, and eight in the other holder for 12 volts.

The Tuning Control is a smooth vernier drive mechanism, giving precise settings of both metal and mineral.

ROD AND LOOP ASSEMBLY

Note Rod Mounting Bracket is located on the bottom of the instrument. The Rod has two sets of Retainer Pins in it, (See Figure #1). One set located in the large end for locking the rod in place, to the bottom of the instrument. The other set located in one end of the small section for locking the two sections of Rod together.

To extend the rod, depress the two pins located in the small rod. Pull the small rod out of the large, align the retaining pins to match the holes in the large rod which has the small rod extending from it, snap in place. Place the loop on the free end of the small rod, removing the thumb nuts from the mounting bolts on the loop. Insert them through the holes in the small end of the rod, install the thumb nuts on the mounting bolts, finger tight.

Operating Instructions Goldmaster Model 63TR

Inserting the large end of the rod into the mounting bracket on the bottom of the instrument, depress the retaining pins and align to match mating holes. Lock into place. Spiral the loop cable snugly around the rod.

Plug the loop cable into the socket on the front end of the instrument. This socket and plug are marked with yellow alignment dots. Align these dots and insert the plug. This plug and socket are also keyed to allow mating with only the correct pin arrangement.

BATTERY INSTALLATION

Now open the battery compartment by releasing the latches on each side and swinging the door open from the top. Free the battery connectors by removing the tape. Note one white connector and one black. Also, a white battery holder (8 cells), and a black holder (6 cells). The white is 12 volt D. C., and the black is 9 volt D. C. Be sure and match white to white, and black to black. Snap the battery connector onto the battery holder, noting the connector and battery holder are set up to match in only one polarity. Be sure to observe this polarity because damage can be done to the electronics if forced together in error. (See Battery Diagram)

TESTING OF BATTERIES

To test your batteries, turn the POWER SWITCH on and your battery check switch to each Battery Check position in turn and note the readings. Good batteries will read between 30-40 on the meter. When your reading drops to 30 on the meter it is time to replace that set of batteries.

Batteries should be tested prior to your regular hunting ventures and once a day during periods of heavy usage.

The Battery Check Switch should be in the OFF position except during testing and trouble shooting. IN THE OFF POSITION THE METER FUNCTIONS AS AN INTENSITY METER.

CONTROL SETTINGS

Adjust the Metal-0-Mineral Control to -0- (Null), the Battery Check OFF, Volume control 3/4 turn clockwise (to the right), and turn the Power Switch ON. These settings are for the initial set up, details follow.

METAL SETTINGS

The Metal-0-Mineral Control adjusts the level of sensitivity as well as selecting Metal or Mineral. Very slowly rotate this control counter-clockwise (LEFT) for a metal setting. Note there will be a sudden change at which point you hear a weak tone. This point we will call the threshold point or level. The threshold level is the best setting for maximum effective sensitivity.

Operating Instructions Goldmaster Model 63TR

For effective results, these adjustments must be made with the instrument in hunting position, (see Figure B, under Operating Illustrations), holding the loop as close to the surface of the area to be explored as is practical for movement of the loop. You are now adjusted for detecting metal.

MINERAL SETTINGS

Mineral settings are made by rotating the Metal-0-Mineral control clockwise (RIGHT to the threshold point which will occur the same as when tuning for metal, but now your responses will indicate mineral. The other controls function the same for both mineral and metal. (See false readings under interpretation of signals, if you feel your instrument responds to both metal and mineral on the same setting.) You are now adjusted for detecting minerals.

HUNTING METHODS AND TECHNIQUES

For Metal Detection set the instrument on the METAL side of null, adjust the volume to the desired level and meter to the correct reading.

When passing the loop over a non-magnetic conductive metal, such as the metal sample you received with your instrument, the sound will increase in the speaker and a higher reading will be retained as long as the loop is held over the metal object. As soon as the loop passes away from the metal object, the sound will lower in volume and the meter will lower in reading, and return to approximately the same reading as before the object was detected. No reading will be had when passing the loop over the mineral sample.

Tin cans, bottle caps, tin foil, aluminum foil, cartridge cases, coins, silver gold, copper, lead and brass are some of the high conductive metals that will read on the Metal setting.

The instrument is not designed to react to sticks, rags, bones, paper, non-magnetized rocks, nor other non-magnetic objects or non-mineralized objects.

When looking for small metal objects, such as coins, the ability of the instrument to detect them will vary in different areas. The more mineralized the soil, the more difficult it is to detect them, and the less mineralized, the easier. Also the longer the metal object has been buried, usually the easier and deeper it may be detected, as the ground becomes electrically conductive from the metal object over a period of time. In some cases you may detect a very old tin can and after digging it up, still receive a reading over the spot the can was buried in.

To locate hidden or buried metal objects, slowly and systematically sweep the loop across the area to be checked, being very careful to hold the instrument so that the loop is held at as constant and uniform height as possible with the least up and down variation in relation to the formation or ground you are using the instrument over. When searching for small objects, such as a single coin, the instrument should be tuned in with the loop held as close to the ground as possible. Hold this height as close as you possibly can, and search the ground carefully, usually on the surface, if possible, depending on the surface you are using the instrument over. If the ground is rough, you may have to zero the in-

Operating Instructions
Goldmaster Model 63TR

strument in higher. For larger objects, one can hold the instrument approximately 1 to 2 inches above the surface to be explored. Keep repeating this process until you have explored the entire area. With each sweep of the instrument you will cover approximately 6 feet by 3 inches. If there is anything under the surface, and it is within detectable range of the instrument, you should be able to find it.

In the short green grass, such as a lawn, it is possible to place the loop on the grass, tune it in, and slide the loop over the grass to locate the smaller objects. The loop automatically is kept at the same height by the grass, so a uniform and more constant meter reading may be maintained, which is important for the very small objects. For large objects, the instrument may be carried at a higher elevation, and it is not so critical to height variation, and will respond to the larger metal objects. To practice, lay some metal objects on a wood floor or on your lawn and move the loop over them, and notice the way the instrument responds.

It is a good policy to slightly adjust the Metal-0-Mineral every 5 to 10 minutes to keep the instrument at its highest peak of sensitivity, when searching for small objects, such as single coins, along beaches, etc., and every 10 to 15 minutes or so for larger objects. This adjustment may need to be made more frequently, if there is a change in the mineralization of the ground you are searching.

The volume is increased by turning the Volume Control to the Right, and is decreased by turning it to the Left. The Volume Control does not increase or decrease the sensitivity of the instrument.

The instrument may be used around water, but do not submerge the loop in water, (unless a waterproof loop has been ordered with the instrument.)

For Mineral Prospecting, set the instrument on the Mineral Side of Null with the desired volume and meter reading.

You may now locate and trace detectable mineralized veins that have all magnetic content with this fine instrument. The instrument will usually read the highest and sound the loudest over the highest mineralized spots in the veins.

It is a good idea to practice with the instrument before taking it into the field. Passing the loop over the mineral sample, you received with the instrument, will cause the meter to read higher and the sound in the speaker will also increase, and this increase in sound and meter reading will remain as long as the loop is held over the Mineral sample. The meter will not read on coins, or on soft conductive metals, (when operated correctly), when set on the Mineral setting, (but will usually read on steel bolts due to their hardness and shape.)

Operating Instructions
Goldmaster Model 63TR

False Readings can occur.

When you feel you are receiving a metal and mineral reaction from the same object, one of them is a false reading.

False Readings occur when an object is too close to the detecting head (loop).

The best method for determining if your reading is false is to move the loop away from the object, then bring the loop closer very slowly. The first indication is the true one.

You may experiment with this phenomenon by taking an object opposite to what you are tuned to, move this object into the field of the loop. Note the decrease in tone. Keep moving the object closer until at approximately 1/2 inch, you will hear a loud blast. This is a false reading. Note the sudden harsh sound of the false reading.

SERVICE - WARRANTY - REPLACEMENT BATTERIES

This model contains two battery holders containing 14 B-1 Batteries. You may order new replacement batteries direct from our plant, if you cannot find them locally.

The new penlight battery system is better in many respects to the old type batteries:

1. Longer life
2. Readily available
3. Superior performance
4. Cheaper in replacement. (If one cell fails, you only need to replace the one cell.)

Replacements: Any AA penlight batteries.

Alkaline energizers and batteries of this type may be used and give even longer life.

Note: All batteries last longer if used in many short periods, rather than in a couple of long periods of use.

When through operating the instrument, turn the Mineral-Metal Control to NULL, (where no sound is heard), and be sure to turn the Power Switch OFF.

The instrument has a full two (2) year warranty on parts and labor (except batteries) to the original purchaser.

If ever in need of service, ship the instrument by insured parcel post, freight or stage, prepaid and enclose a letter advising the nature of your troubles. It may be returned to the factory address listed below, or to one of our Service Centers listed in the back of this book.

Operating Instructions
Goldmaster 63TR

CAUTION: Care should be taken in excessively cold weather to protect the instrument, as well as the batteries from freezing.

The instrument should also be protected from exposure to excessive heat when not in use.

If the instrument is to be laid away for any great length of time, the battery pack should be unsnapped and the pack removed from the instrument and the batteries stored in a dry, cool place, such as on a shelf in a closet. This will prevent damage to the instrument in case one or more of the batteries are damaged or in case the power switch is left on or gets turned on accidentally. The damage to the instrument in this case is similar to what occurs in a flashlight, when the battery is discharged and the liquid escapes to damage the case and components.

WHITE'S ELECTRONICS, INC.
1011 Pleasant Valley Road
Sweet Home, Oregon 93786

Revised 11-01-73

Printed in U.S.A.

OPERATOR'S T.R. TIPS
(REVISED)

With the instrument assembled and ready to operate, bury a coin in the ground approximately one inch down and lying flat. Place the instrument so that the loop is on the ground and horizontal. Next, turn the instrument "on", with it in the Null or "0" position. Start turning the Metal-O-Mineral dial counter-clockwise, until a tone is heard. Now, go back the other way (clockwise) until it just goes quiet.

Now you should be able to move the loop about, without it making any noises, unless it is passing over some metal object. If it is making noises, then you may need to turn it a little more toward the Mineral Setting (clockwise).

Be sure that you are rubbing the loop on the ground and that you are not lifting the edges as you sweep it across the ground. Now, practice on the coin that you buried.

The further counter-clockwise you can turn the Metal-O-Mineral dial, without the instrument giving false readings, the more sensitive it will be.

A demonstration is worth a thousand words - for the best results, see your local dealer and ask for a demonstration.

NOTE: These tips are mainly for beginners and are to be used only as a rough guide. Once the operator gets the general idea of how to operate the instrument, he may want to use it with a slight tone.

BATTERY DIAGRAM

Note:

To prevent damage in shipping, the batteries have been removed from your instrument and placed in a separate container within the shipping carton. See following diagram for proper installation.

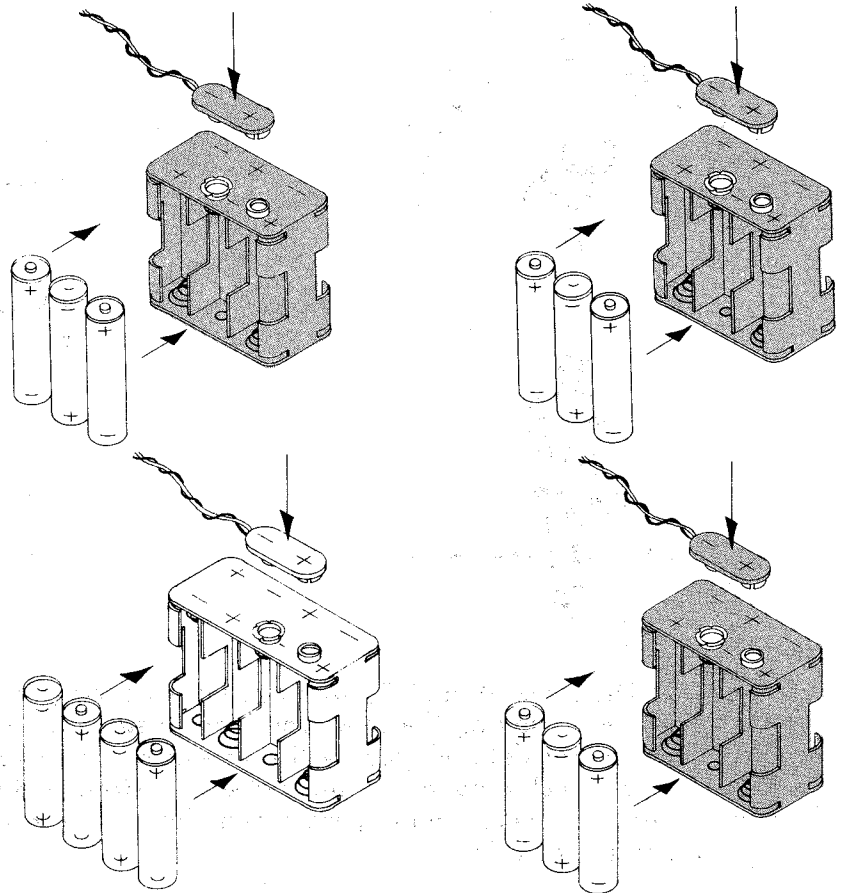
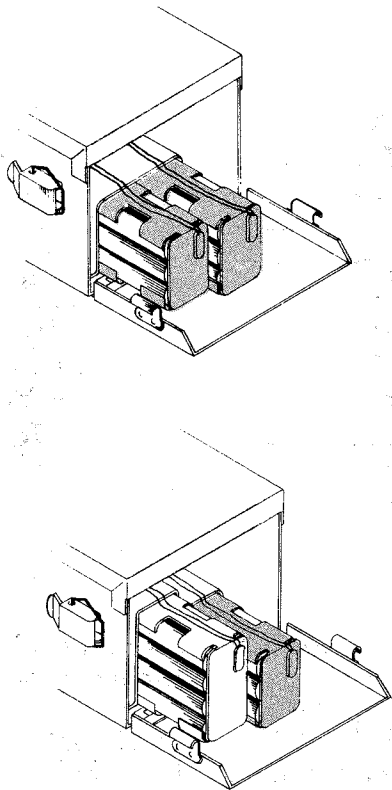

9 volt (6 Pak) Black Connection
12 volt (8 Pak) White Connection

BATTERY-PACK ILLUSTRATION

	EVEREADY	BURGESS	WHITE'S
1.5 Volt "AA" (Battery Pack Models)	1015	910	B-1

When ordering replacement batteries from the factory, please state the instrument model, voltage of batteries and battery number.

ROD ASSEMBLY, DRAWINGS

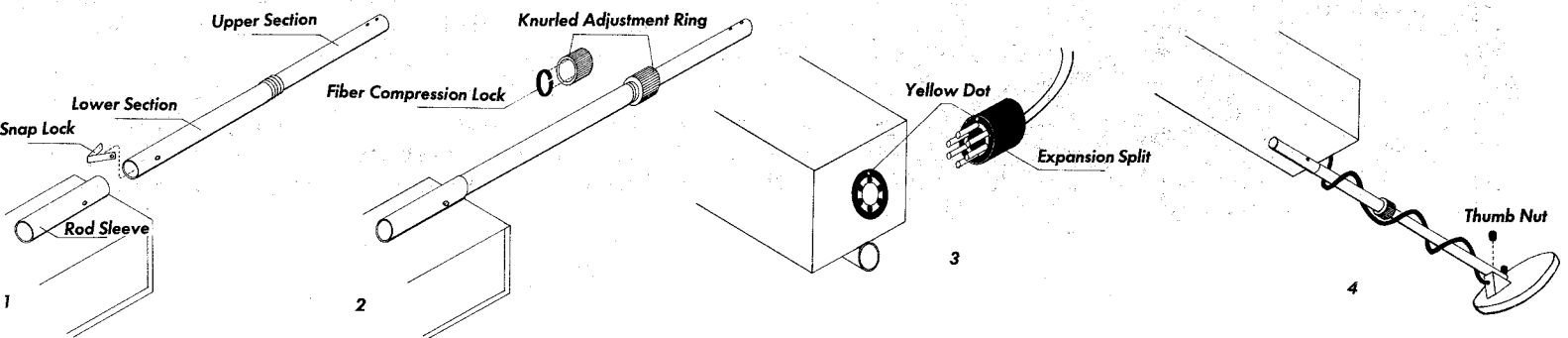

When you receive your instrument with the knurled adjustment rod, it may be necessary to install the snap lock. As illustrated in Figure Number 1. Depress snap lock and insert it in the lower section. Insert the lower section into the rod sleeve.

Figure Number 2 shows the fiber compression lock; make sure it is inside the knurled adjustment ring. Slip the ring over the upper section; adjust rod to desired length and tighten ring as shown.

When attaching the loop cable to the instrument chassis, make sure the yellow dot on the plug matches the one on the instrument. As shown in Figure Number 3 (note: the "Expansion Split", as pictured in Figure Number 3, is to allow assembly and disassembly of the plug cap and is not a manufacturer's defect).

Attach the loop with the thumb nuts as shown in Figure Number 4. Always coil the loop cable as snugly as possible, without pulling or stretching it.

OPERATING ILLUSTRATIONS

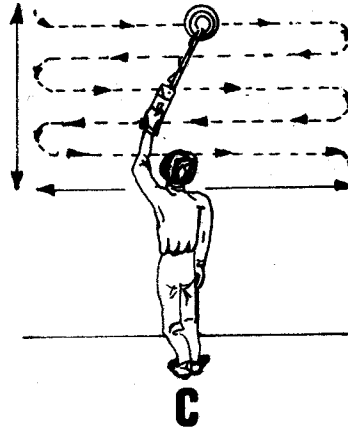
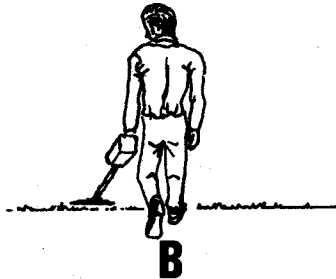
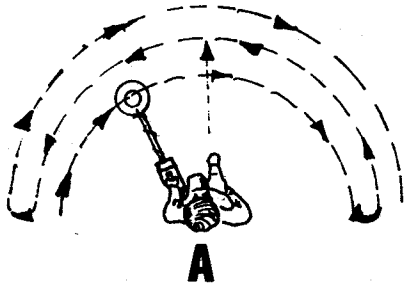

As shown in Diagrams A and B, when you are working on the ground, move forward in a straight line, at the same time, moving the loop from side to side across in front of you. The distance between each swath of the loop is determined by the size of the loop you are using. With a 6" loop you would make a 3" step, with 12" loop you would make a 6" step, and so on. Using this method of hunting enables the hunter to cover more ground, more completely, in less time. For tuning your loop, hold it as close to the ground as possible.

Diagrams C and D show you just one more of the many ways the versatile design of the White's instrument can help you either in prospecting or treasure hunting. This diagram demonstrates the extra ability the design gives in reaching to the out-of-the-way places. This system can be used for checking outcroppings, walls, etc,

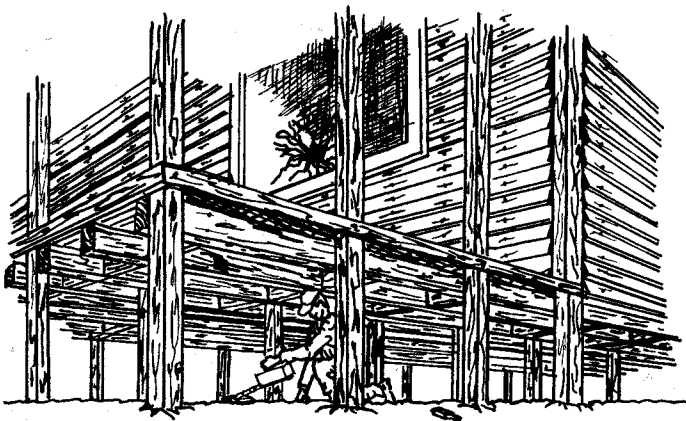

Remember, a lot of old artifacts and treasure have been found under old buildings, as well as in the attics. When going through an old homestead, never overlook any place or area that could represent a good hiding place. So if you are planning such a trip, follow these simple illustrations and prepare your instrument. At a time like this you don't want to pass up any chances.

Proper Care of Your Detector

The following are precautions you should take to protect your instrument from harm, insure its long life, and avoid nullifying the warranty.

Cleaning: The loop and rod or probe are waterproof. They can be cleaned with fresh water and a mild cleanser. After cleaning, however, dry the instrument thoroughly. Caution! The instrument case is not waterproof, and water—if allowed to enter it—may damage electronic components.

Weather Conditions: Protect your detector from excessively cold weather. Freezing can damage the electronic components, the case and/or the batteries. Excessive heat can also damage the instrument. Never leave it in the sun. It's best to lay it in the shade when temporarily not in use. If it's left in a car on a hot day, cover it with a blanket or something similar to protect it from the direct rays of the sun, and then leave the windows slightly open to permit ventilation. Needless to say, protect your detector if you operate it in the rain, as water may get into the instrument case.

Salt Water: Salt water is very corrosive! Immediately after your detector has been exposed to salt water, rinse it thoroughly with fresh water, being careful not to allow water to enter the instrument case. Then wipe it with a cloth dampened with fresh water and dry it thoroughly.

Storage: If you plan to store your detector for any length of time, unsnap the battery and remove it from the instrument. Whenever your detector is not in use, turn the **VOLUME** knob all the way to the "**PWR OFF**" position.

Service And Warranty Information: If your new metal detector is ever in need of service, ship it to us at the factory address below or to one of the Service Centers listed on the back of the warranty statement. Insure it fully, prepay the charges, and enclose a letter describing the nature of the problem. As long as your detector is under warranty there is no charge other than a small handling and postage fee.

Read your warranty card carefully. It describes completely what is covered and the length of the coverage. If you have any questions don't hesitate to write us. We will be happy to answer any questions you may have.

HELPFUL HINTS AND TIPS

1. "How deep will it go?" Detection depth is determined by five main factors.
 - a. The **SIZE** of the object.
 - b. The **SIZE** of the loop.
 - c. The **LENGTH OF TIME** the object has been buried.
 - d. The **SKILL** of the operator.
 - e. The ground **MINERAL CONTENT**.

The longer an object has been buried, the better you will be able to detect it. A chemical reaction called a "halo effect" between such objects as silver or copper coins and the surrounding soil may cause your detector to register a much larger increase in volume than might otherwise be expected for a small coin. If the halo effect is strong enough, your detector may continue to register even after you have dug up the coin.

2. "What will my detector locate?" Silver, lead, copper, bottle caps, tin foil, pull tabs, cartridge cases, rings, brass and tin cans are just a few of the conductive objects that can be detected. Your detector will not locate sticks, rags, bones, paper, wood or other non-metallic objects.
3. Learn how to interpret the different types of responses from your detector. A nail lying flat in the ground will sometimes produce a double or single reading depending upon whether your loop passed across it lengthwise or across its width. So it's a good idea to sweep your finds from several different directions to try to learn as much as possible about the object you have located. Coins will usually only produce one reading regardless of sweep direction.
4. Rather than waste time, check around the trees for junk items such as foil, pull tabs, bottle caps, etc. This will frequently indicate whether or not someone has already been in the area with a detector.
5. Always "criss-cross" an area when hunting it.
6. After you have dug up a coin, always check the hole again for more. As many as 10 coins have been found in one hole!
7. When beachcombing the best place to look for coins is near the concession stands.
8. Check the shallow water in swimming areas. Most rings and coins are lost when people enter the water.
9. If you make plans for coinshooting, check the history records of the area.
10. Always carry a plastic bag for your detector in case you get caught in the rain.
11. Never ask permission to treasure hunt over the phone. People tend to visualize you using a pick and shovel, making large holes.
12. Join a local historical society or get acquainted with its members.
13. In lawn areas, use a screwdriver of no more than eight inches as your tool. Limit the size of the hole to a **MAXIMUM** of two inches in diameter. Don't forget to fill in the hole. Public and private officials and property owners will be more likely to allow continued treasure hunting if you do no environmental damage.

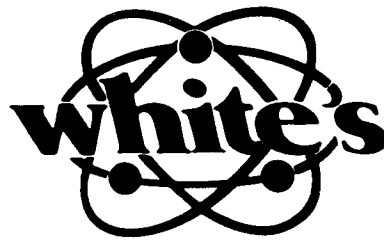

1011 Pleasant Valley Rd.
Sweet Home, Or. 97386