

GOLDMASTER AMPHIBIAN

MODEL BF-8

Operators Instructions

To Operate the instrument, proceed as follows:

- (1) Insert the curved key, on the inside of the speaker plug, into the slotted opening in the socket, so that the 5 holes in the plug match and slip over the 5 pins in the socket.

Slowly revolve the outside sleeve on the plug to the right, (clockwise) with a slight forward pressure, until the retainer slips into the retainer groove. Continue turning, to the right, until the pin locks into place with a distinct "click". This makes a watertight connection. If the sleeve is not turned to the right far enough, until this click occurs, the connection is not watertight. (Be sure that the 5 holes and 5 pins are in proper alignment and are inserted before the sleeve is rotated to prevent damage to the pins.) To remove the speaker, revolve the sleeve to the left.

- (2) Slip on the helmet with the underwater speaker, so that it is over the right ear.
- (3) Turn the single Mineral-Metal Control knob so the marker line is pointing to the Null position, which is located between the Metal and Mineral Lettering.
- (4) Snap the Power Switch to the ON position by pushing the switch handle to the Right.
- (5) Slowly revolve the metal and mineral control knob to the Right toward the metal setting, (counter-clockwise), until a motor-boating sound just starts in the speaker. (When making this adjustment, be sure to hold the instrument away from any metal object.)

Pass the front end of the instrument near any metal object and the frequency (speed) of the beat will increase, as long as the instrument is held close to the object. The motor boating will also continually increase, as the instrument is moved closer to the object. Moving the instrument away from the metal object will reduce the motor-boating sound, back to the original frequency (speed) of the beat.

METAL SETTING

When the instrument is set on the Metal setting the speed of the tone will decrease over magnetic minerals and black magnetic sand and will increase over any conductive, non-magnetic metal.

MINERAL SETTING

When the instrument is set on the Mineral setting, the speed of the tone will increase on magnetic rocks and black sand and decrease over conductive metal of all kinds.

SENSITIVITY

The most sensitive part of the instrument is in the Center of the round disk, in the front end of the instrument. With the instrument, you received a Mineral and Metal test sample. Notice that in passing the metal sample (coin) closely over the front of the instrument, the frequency of the sound increases and is the fastest at the Center of the disk. This disk contains the search coil of the instrument, from which the Radio Waves are emitted.

Passing the mineral (magnetic) sample, closely, over the search coil, will cause the sound to slow and stop.

Turn the Metal-Null-Mineral Control Knob to the Right, toward the mineral side of null, until the motor-boating sound just starts. Now pass the mineral sample close to the search coil. This will increase the frequency (speed) of the sound, at the center of the coil. Passing a coin over the coil will decrease or stop the beat, depending on the closeness of the object to the coil.

WATER TEMPERATURE

For normal temperatures, the point of Null (where no sound is heard) is where the pointer of the Control Knob is centered on Null, just above it, but this point of Null can move to the right or left of the normal null in extreme temperature changes, should the water be exceptionally cold, or exceptionally warm.

NULL POINT

Should this occur and the point of Null is not at the TOP and a tone is heard in the Null position, it may be easily found by simply turning the control knob in the direction that the tone slows in sound and frequency, until the sound stops. This will be the New Point of Null, for this temperature. From this position, the metal setting will always be found by turning the control knob to the LEFT, until the tone just starts and to the RIGHT for the Mineral (magnetic) setting. So, regardless of where the point of null may move, the metal setting is always on the LEFT of it, and the mineral on the RIGHT, after the null is found.

When finished using the instrument, be sure to push the OFF - ON Switch located just ahead of the handle, to the OFF position.

CARE AND MAINTENANCE IMPORTANT!! See Special Note.

After using the instrument in salt water, it should be rinsed off, to remove the salt brine from the case and particularly from all the metal parts.

The groove in the socket for the underwater speaker should be kept lightly coated with Vaseline for the smoothest installation and removal of the plug.

The large Rubber O ring should be kept clean and with a light coating of Vaseline applied to insure a water tight seal.

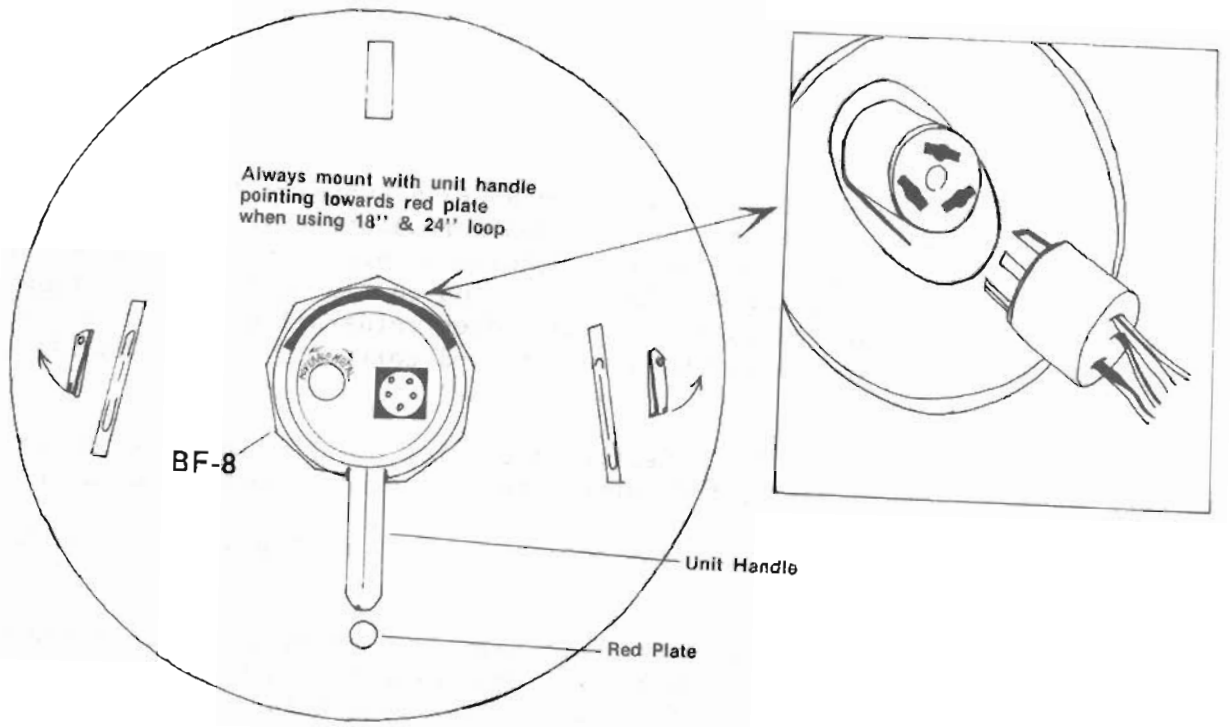

Amphibian Goldmaster
BF-8 UNITS

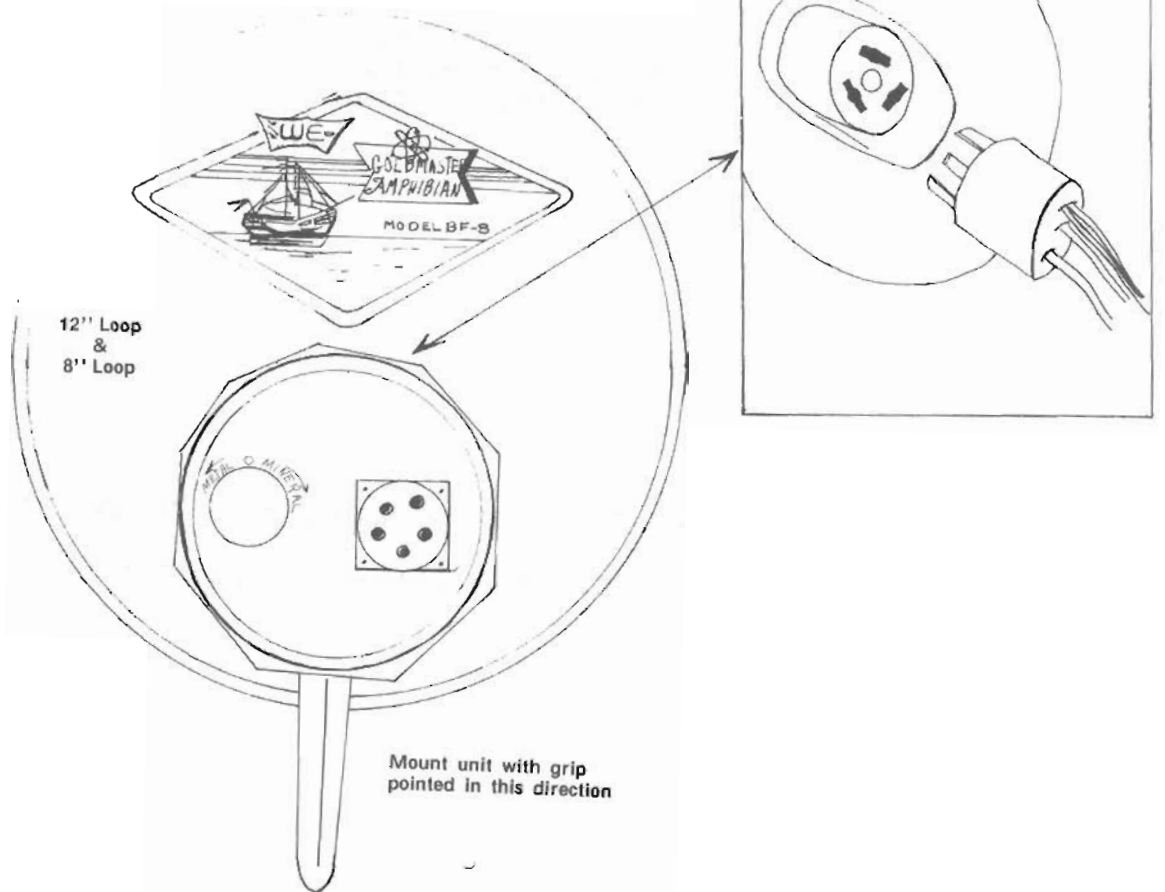

REPLACING THE BATTERY

This instrument is powered by a single 9V #246 Eveready Battery. To gain access to this battery, first remove the loop (or adapter) by unscrewing the large red plastic retainer ring in a counter clockwise direction then remove the loop (or adapter) by pulling on the knurled brass stud in the center of the loop. (Note location of the larger rubber O Ring. When reinstalling the loop (or adapter) be sure the rubber O ring is clean and positioned correctly on the shoulder in the main housing [or case].)

Disconnect the loop by disconnecting the three prong plug. Disconnect the battery connector by releasing the battery holding band. Remove the battery.

Install the new battery and reassemble by following the above procedure in reverse order.

When laying the instrument away, care should be taken to see that the switch is not accidentally snapped on, which will discharge the battery if left on over several hours. If you are going to store the instrument for a long period of time, it is a good policy to remove the battery.

The Speaker Plug should be kept clean of any brine, or corrosion, by rinsing in fresh water, while left attached to the instrument. The same holds true of any external probe that may be used. There are also a number of accessories available for the BF-8, which includes Probes and various sizes of loops.)

If in need of service, pack the instrument carefully, insure it, and return the instrument to the factory Service Center.

White's Electronics, Inc.
1011 Pleasant Valley Road
Sweet Home, Oregon 97386

SPECIAL NOTE:

IMPORTANT - BE SURE TO LUBRICATE THE O RING BEFORE USING THE INSTRUMENT OR WARRANTY AGAINST WATER LEAKAGE IS VOID. USE PARKER O RING LUBE OR VASELINE.

Adapter For

AMPHIBIAN BF-8

Instructions for using Probe

To install the Adapter Disk, for use with External probes:

- (1) Unscrew the large plastic retainer ring on the front of the instrument by rotating counter clockwise (to the left) and remove it.
- (2) Loosen and remove the disk in the front of the instrument.
- (3) On the opposite side of the loop disk from the battery, you will see a black, round plug with 4 wires going into the top of it, and marked 1-2-3. Grasp this plug by the small rim at the top edge and carefully pull it from the round black socket it is plugged into. This completes removal of the 4" loop.
- (4) Install the probe adapter by first inserting the three prong plug into the mating socket on the probe adapter. Then place the adapter in the housing, making sure the rubber - O - ring is positioned correctly on the shoulder, just inside the housing, with the adapter grove also in the correct alignment.
- (5) Place the large plastic retainer ring on, using a clockwise rotation for tightening.
- (6) Connect the probe plug to the mating socket on the adapter.
- (7) Connect the head phones. BE SURE TO USE THE UNDERWATER TYPE WHEN WORKING UNDERWATER AND THE REGULAR HEAD PHONE FOR LAND OPERATION.
- (8) Turn the Power Switch ON (to the right). Tune the instrument as described in the BF-8 Instruction book.

The shoulder strap is clipped to the 2 suspension rings. The strap slips over the head and adjusts to the most convenient position and height.

BFX4 - BFX6 Probes: The probe is carried in the hand for both dry use and for beach combing.

To use the Probe

The probe should be held with the bottom of the loop just above, and flat with the surface, usually one to two inches above the surface to be searched, then tune the instrument in on the Metal side of Null and maintain this height as closely as possible when using the Probe. Do not raise or lower the probe anymore than necessary for the most accurate response and to avoid false signals.

If the Stereo Head Set is used, it is plugged in the same as the under water speaker and while it has the Submarine connectors, the same as the under water speaker, this is NOT an underwater head set. DO NOT SUBMERGE THE STEREO HEAD SET IN WATER.

The BFX4 Probe makes an excellent prospecting instrument of the Amphibian BF-8, for land use, as well as for beach combing. The BFX6, while a little heavier usually gives a little deeper detection for coins, rings and other small objects. When using the BFX4 Probe, it should be held not more than 1" above the surface in beach combing. Deepest detection is had by holding the loop as close to the surface as is possible and practical for movement.

To search for magnetic veins and ore bodies, the instrument should be tuned in on the Mineral Side.

To search for coins, rings, gold copper and silver nuggets and other metal objects, use the instrument on the Metal side of Null.

To remove the adapter and to replace the standard 4" Loop disk, reverse the adapter installation procedure.

White's Electronics, Inc.
1011 Pleasant Valley Road
Sweet Home, Oregon 97386

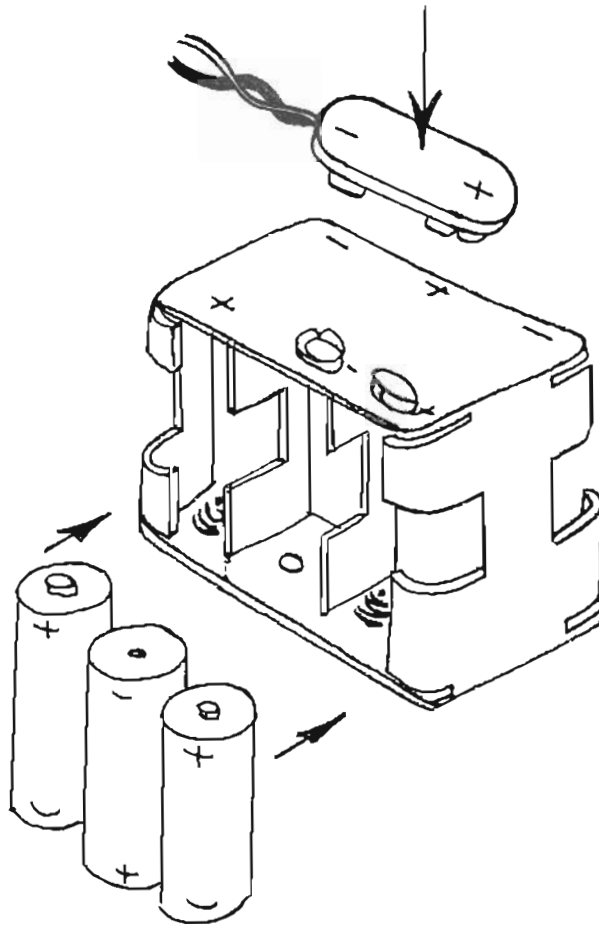

Battery Pack Illustration

1.5 Volt "AA" (Battery Pack Models)

EVEREADY

1015

BURGESS

910

WHITE'S

B-1

When ordering replacement batteries from the factory, please state the instrument model, voltage of batteries and battery number.

OPERATING ILLUSTRATIONS

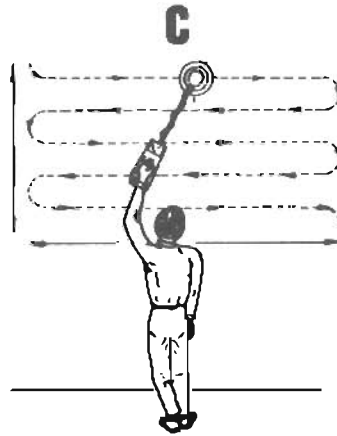
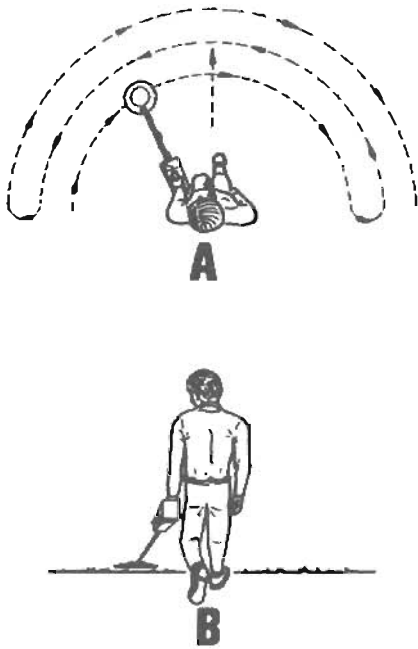

As shown in Diagrams A and B, when you are working on the ground, move forward in a straight line, at the same time, moving the loop from side to side across in front of you. The distance between each swath of the loop is determined by the size of the loop you are using. With a 6" loop you would make a 3" step, with 12" loop you would make a 6" step, and so on. Using this method of hunting enables the hunter to cover more ground, more completely, in less time. For tuning your loop, hold it as close to the ground as possible.

Diagrams C and D show you just one more of the many ways the versatile design of the White's instrument can help you either in prospecting or treasure hunting. This diagram demonstrates the extra ability the design gives in reaching to the out-of-the-way places. This system can be used for checking outcroppings, walls, etc.

2

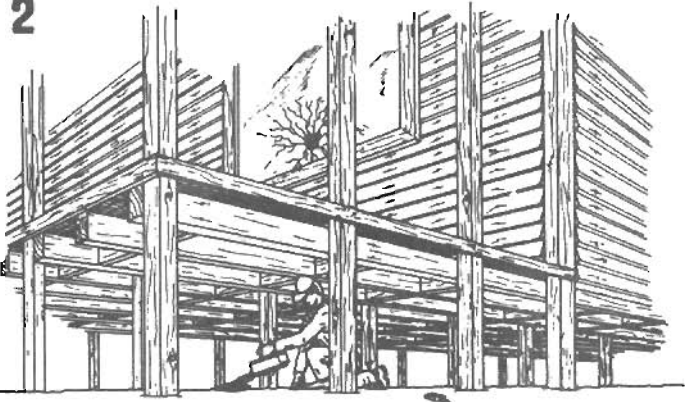

Remember, a lot of old artifacts and treasure have been found under old buildings, as well as in the attics. When going through an old homestead, never overlook any place or area that could represent a good hiding place. So if you are planning such a trip, follow these simple illustrations and prepare your instrument. At a time like this you don't want to pass up any chances.

America's Largest Line of Metal Detectors



WHITE'S ELECTRONICS, INC. 1011 Pleasant Valley Rd., Sweet Home, Or. 97386

Printed in USA