

Surf P.I. Pro Table of Contents

- Assembly 2
 - Assembly Instructions 3
- Batteries 4
 - Installing Batteries 4
 - Testing Batteries 4
- Controls 5
 - Gain Control 5
 - Tuner 5
- Operation 6
 - Background 6
 - Dry Sand Searching 6,7
 - Searching in Salt Water 8
- Information 9
 - Proper Care 9
 - Service 10
 - Warranty 11
 - Warranty Transfer 12
 - Video 13

Assembly

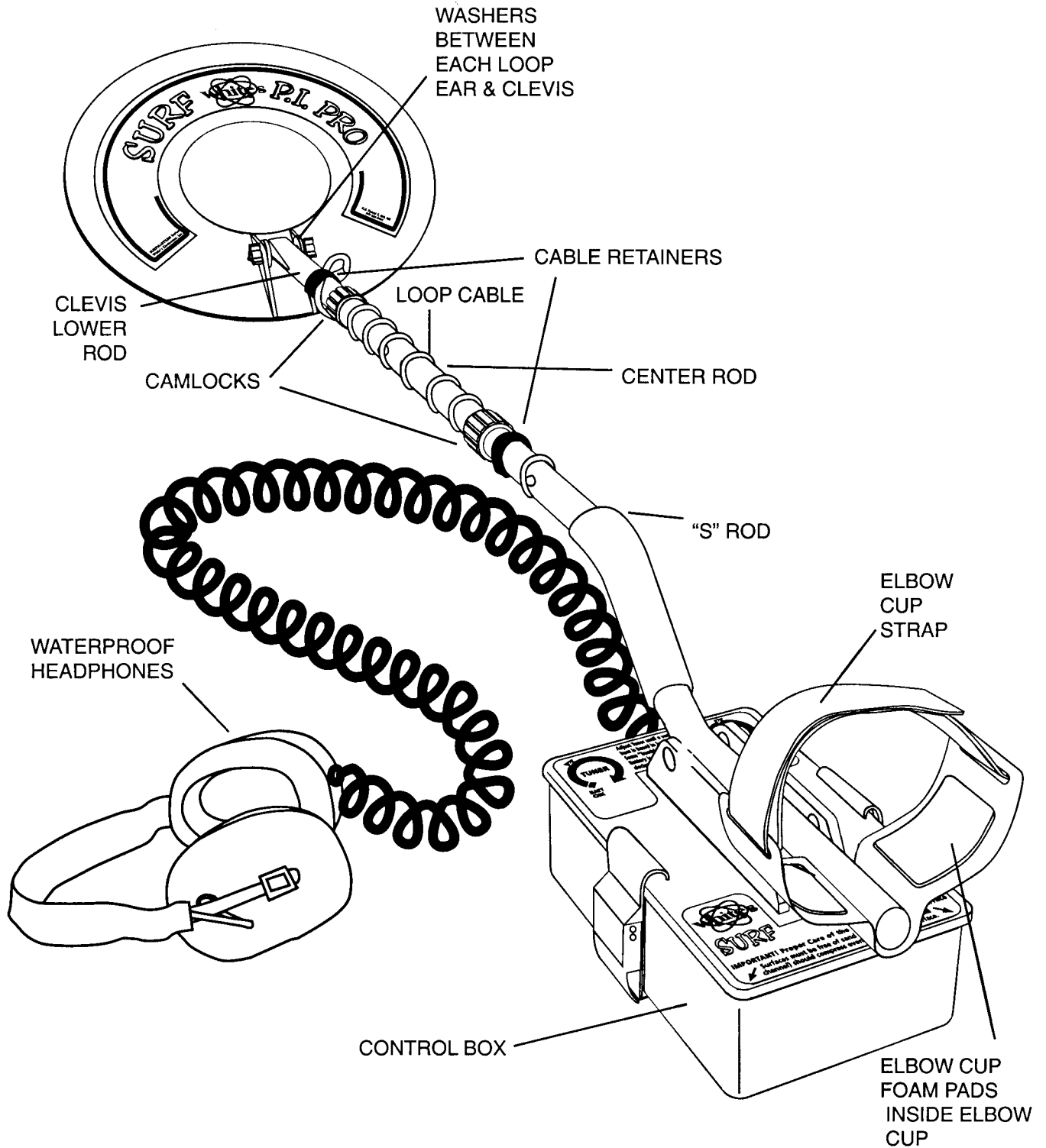

Assembly Instructions

1. Remove all parts from shipping carton and check the assembly page to make sure all parts are present. Remove control box from the "S" rod by compressing both the spring clip buttons on one side of the rod and pivoting the control box off.

For superior water proofing, the Loop, Headphone, and their cables are hard wired (not removable) from the control box, headphone and loop. The waterproof fitting and strain reliefs on the cables are torqued to a specific ideal setting and should not be loosened or tightened. Extra care/effort must be taken in assembly regarding winding the cable around the rod.

2. Unlock "S" rod camlock and insert the reduced end of the center rod into curved "S" rod so that stainless steel spring clip buttons line up and lock into the holes in the curved "S" rod. Turn camlock to secure.

3. Fit the rubber washers between clevis/lower rod and searchcoil ears. Use only non-metallic washers, fiber bolt, and thumbnut, to secure loop to clevis/lower rod. Then insert into center rod so that stainless steel spring buttons line up and lock into one of the adjustment holes in the center rod. Turn Camlock to secure.

4. Unravel cable and wind the cable around the clevis and rod assembly, first revolution should be OVER the top of the rod with some slack before applying the cable retainer. This is done so that the search coil can be paddled backwards toward the rod without putting a strain on the cable. Wind cable firmly all the way to the curve in the "S" rod. Then attach control box to the rod by compressing the two spring clips on the rod aligning and inserting control box lid bracket. To secure cable, wrap velcro cable retainers around rod and cable, one near the searchcoil and one near the padded handle on the "S" rod.

5. Grip the instrument by the handle, with your arm in the elbow cup with strap secure, and sweep the coil over the floor. If the instrument fit feels uncomfortable, adjust the elbow cup by removing and repositioning the bolt/thumbnut and installing in one of the optional positions. If necessary, readjust clevis/lower rod length with the spring clip buttons so that the searchcoil can be held near the floor without requiring stooping over.

6. Adjust the elbow cup strap so that it is loose enough for you to slide your arm in and out without loosening each time you want to set the detector down. Peel and stick elbow cup foam pads on the inside of the elbow cup, one on each side.

7. Install batteries as described in the next section.

8. This model can also be worn as a hipmount simply by removing the control box from the "S" rod, adjusting the length of cable wound around the rod, and weaving your belt through the slots on the bottom of the control box.

9. It should be noted at this point that the detector may not work as expected indoors due to the high degree of metals (nails, pipes, etc.) used in modern construction and the presence of electrical interference. It is best to tune and practice out-of-doors to ensure stable, predictable results.

Batteries

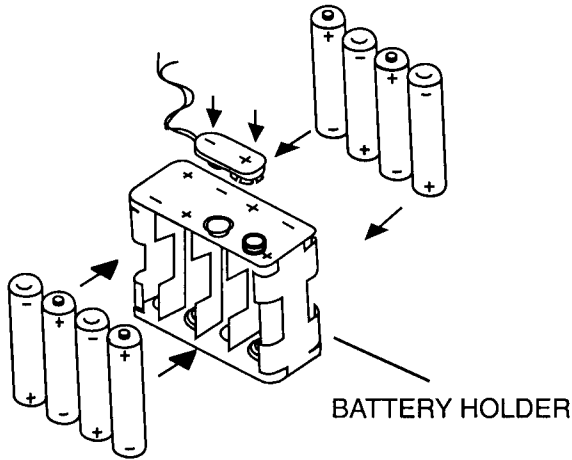

Installing Batteries

The Surfmaster P.I. Pro is powered by eight AA Penlight batteries. Alkaline cells are recommended.

Lift the latches on the sides of the case and remove the lid, using care not to lose or damage the "O" ring seal, located on the lid. Remove the battery holder from the parts bag and install the penlight batteries. Connect the battery lead to the pack and put the pack into the case. Clean any dirt or sand from the "O" ring, case and lid. Replace the lid, being sure it is seated properly. Close the case latches. Look at the "O" ring to be sure it is compressed and seated properly on the lower case surface.

NOTE: Improper assembly of the case can cause it to leak and may damage the detector.

Standard carbon-zinc or heavy duty batteries will last for approximately 15 hours. Alkaline batteries are recommended and should provide 25 to 35 hours of continuous operation. White's has a high quality rechargeable system available for the Surfmaster PI Pro that will provide up to ten hours per charge. Please contact your Dealer or White's directly for further information. Battery life will vary with changes in temperature, number of target responses, as well as battery type.

Testing Batteries

A battery test can be performed with the TUNER control. When the TUNER is turned fully counter-clockwise until it clicks, the audio battery tester is turned on. The condition of the batteries is indicated by the volume of the "beep". When the batteries are new a loud "beep" is heard. The "beep" will become weak when the batteries need to be replaced.

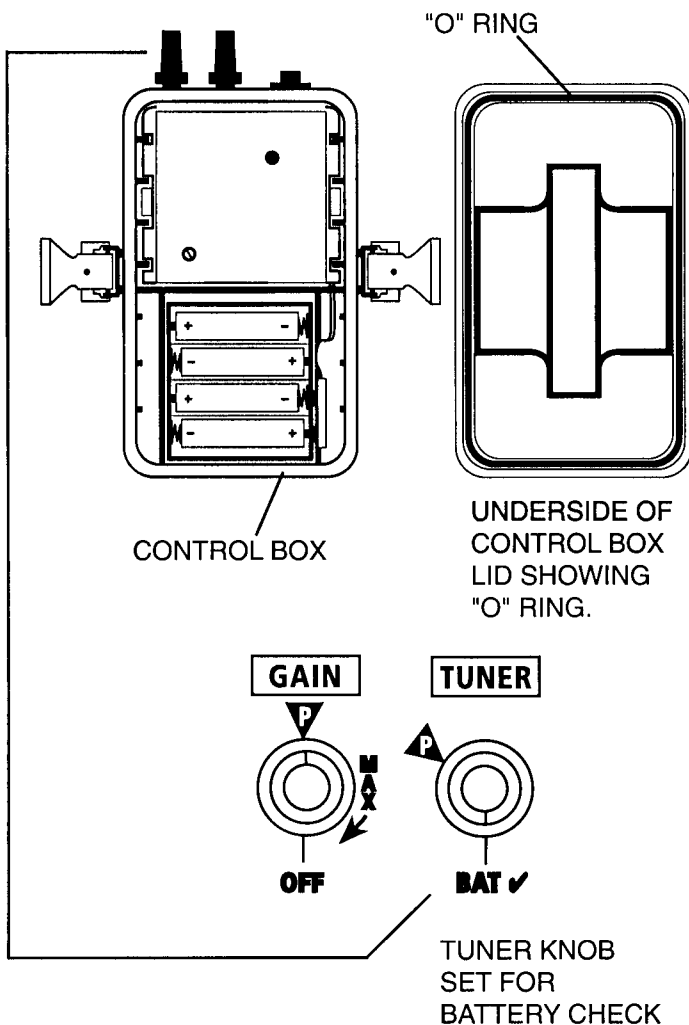

Controls

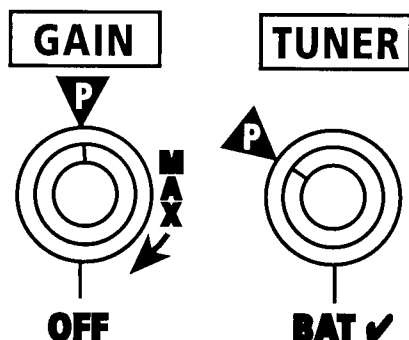

THE "P" IN THE TRIANGLE REPRESENTS THE OPTIMUM SETTING THE FACTORY RECOMMENDS FOR MOST SEARCHING

Gain Control

The GAIN control turns the power ON and OFF and is used to select the responsiveness (sensitivity) of the Surfmaster PI Pro.

High ground mineralization or electrical interference in the search area may require a decreased level of Gain to stabilize responses to be both predictable and reliable.

Low mineralized areas and/or areas of little electrical interference may require increased levels of Gain for the best performance. At the maximum setting some instability may be expected depending upon electrical noise in the area. The recommended setting is the furthest clockwise setting that allows smooth predictable responses.

Tuner

The TUNER is used to adjust the background hum (threshold). The threshold is the low hum you hear when you are not detecting a target. The TUNER should be adjusted so that you can hear a slight hum (edge of sound). If the hum is set too loud, it may mask some of the deeper targets. If it is set too low, some of the deeper targets may not be heard. The TUNER also functions as a sensitivity control. Setting it for silent operation will reduce sensitivity eliminating noise from nearby detectors or other electrical sources, however, some reduction in detection depth can be expected.

We could have made the threshold "preset" at the factory. We chose not to because no two people hear things the same way. When you are hunting in dry sand in a quiet area, you can set the threshold very low. If you are near the surf or in a noisy area, you may have to increase it slightly to hear it.

Operation

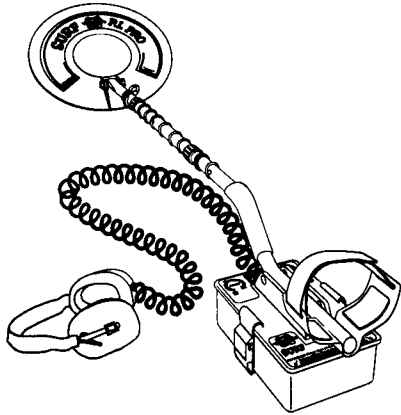

Background

The Surfmaster P.I. Pro has been enhanced with increased performance over past Surfmaster PI models. It is a high-performance user-friendly metal detector, waterproof to an underwater depth of 100 feet, operating on the Pulse Induction principle. It is capable of extreme detection depth on coins and jewelry in salt water and mineralized ground. In the past, P.I. metal detectors had to be swept very slowly for maximum depth and they had very poor sensitivity to copper-nickel coins and gold. They had manual tuning which was critical to adjust and prone to drift. Most used a VCO or "fire siren" type of audio tone which changed from a low growl to a squeal when a target was detected.

The Surfmaster P.I. Pro is different. It is the result of over fifteen years of research and development. Our goal was to develop a Pulse Induction metal detector which could match the sweep speed, sensitivity, stability and ease of use of an Induction Balance VLF without responding to wet salt or mineralized ground. The Surfmaster P.I. Pro may be swept either quickly or slowly with virtually no loss in sensitivity. It was designed to be more sensitive to gold and copper-nickel alloys than to other metals.

Dry Sand Searching

The Surfmaster P.I. Pro operates on the Pulse Induction principle. Unlike an induction balance detector, it does not require any ground balance adjustments. Most P.I. instruments must be swept very slowly in order to achieve maximum depth, but the Surfmaster P.I. Pro, does not. It was designed to have a fast target response, so it can be swept almost as quickly as an Induction Balance (VLF) detector.

When you lower the loop to the ground, you should not hear any change in the threshold tone. Mineralized ground might cause a slight response, but the S.A.T. circuit will compensate for it. Sweep the loop from side-to-side and listen for any increase in the threshold tone. Try to keep the loop level about one inch above the ground. Any repeatable signal, no matter how faint, should be investigated. The loop needs to be in motion continually during searching.

The Surfmaster P.I. Pro loop field is shaped somewhat like a half-circle rather than the more familiar "V" or funnel. For maximum coverage, you should overlap your sweeps by at least 50%. Targets can also be detected outside the edge of the loop depending upon their depth and position with relation to the coil plane.

The Surfmaster P.I. Pro has fast Self-Adjusting Threshold. Once the threshold tone has been adjusted, the S.A.T. system will maintain it. If you stop the loop over a metal target, the S.A.T. will tune it out and return the detector to the threshold tone. If you move off the target, then back on, the detector will re-tune giving a response. For this reason, the loop must be kept in motion while detecting or pinpointing a target.

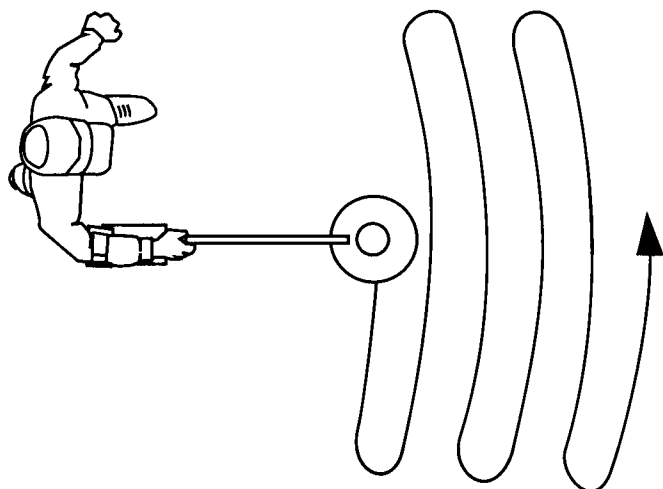

CONSTANT 3-5 FOOT PER SECOND
OVERLAPPING SWEEP
WITH THE LOOP LEVEL, 1" ABOVE THE
GROUND

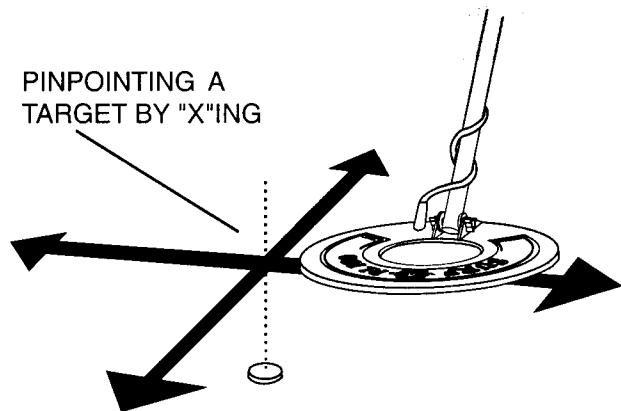

PINPOINTING A
TARGET BY "X"ING

If you are searching an area that has produced valuables, or has the potential for producing valuables, cover the area at least twice. Search first in one direction and then again at a different angle 90 degrees from the first. Some targets, such as coins on edge, may only respond from one direction.

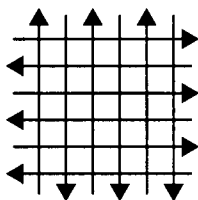

The sweep speed affects the performance capability of the detector. If you sweep too slowly, the S.A.T. will attempt to tune out a detected target. The result will be a loss in depth. If you sweep too quickly, the detector may not respond to a detected target also resulting in a loss in depth. The optimum sweep speed is three to five feet per second. In other words, if you sweep the loop in a five foot swath in front of you, you should be able to count "one-hundred-and-one".

You may wish to bottom scrub the loop for maximum depth. Scrubbing is not really necessary and may cause false signals over highly mineralized sand/silt. Scrubbing also causes wear on the bottom of the coil and puts added stress on the coil connecting hardware. If you wish to scrub, you should purchase a protective loop cover. Be sure to remove the cover at regular intervals and clean out any sand or water.

The search coil has a very wide scanning area. When you hear a target, sweep slowly over it until the response is equal as you move the loop back and forth. Pinpoint by sweeping it from two directions, from back-to-back and side-to-side until the response is equal in all directions. If you slow the sweep, you can pinpoint with a good degree of accuracy. The most sensitive area of the loop is in the center.

Shallow targets can be difficult to pinpoint if they overload the coil. Simply raise the loop while "x-ing" the target area. Coins lying flat will usually respond best in the exact center of the loop. Coins on edge, nails and irregularly shaped objects may tend to pinpoint near the outer edge of the loop. If you have trouble locating the target, turn the loop 90 degrees and pinpoint with the edge.

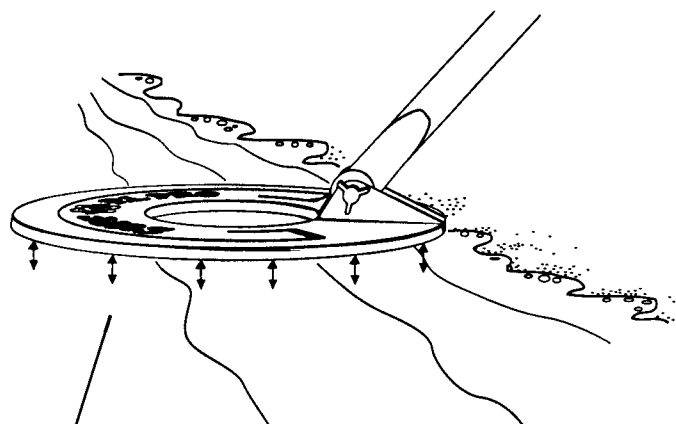

HUNTING AT THE SURF LINE AND HOLDING THE LOOP JUST ABOVE THE WATER SURFACE

Searching in Salt Water

Pulse Induction instruments do not need to be adjusted to ignore the effects of wet salt or ground mineralization. When you plunge the loop into salt water, it will take a second or two for the S.A.T. to stabilize the detector. If you lift the loop out of the water, you will hear a brief tone. This is a normal function of the S.A.T. system.

If you are hunting at the surf line, simply lift the loop just above the water as the wave comes in. This will minimize false signals, plus it is easier to sweep the loop in air than in water. If the loop is dunked in salt water, then pulled out and swept on dry land some false signals may be heard. They are caused by the water droplets moving around on the loop case. You can minimize these noises by treating the loop case with Armor All, silicone spray, or spray wax. This makes it easier to shake off the sand and excess water.

Interpreting changes in the threshold is the key to success using the Surfmaster P.I. Pro. Some very deep targets could cause a subtle beep in the normal threshold. Identifying these subtle changes can be challenging underwater with noise from your air supply. Practice with known targets to become familiar with the way the threshold changes over such sample targets.

Some threshold changes are caused by dramatic changes in the ground, for example placing the loop in salt water. Obvious changes in conditions are easily recognized and the Surfmaster P.I. Pro will quickly and automatically reduce the sound back to threshold. However, less obvious changes may result in some conditions. Decomposed iron, for example, may respond. Such signals must be investigated. Fortunately some idea as to the size of a target can be determined by the size of the area that causes the change in threshold. Remember to keep the loop in motion so that the instrument will continue to respond.

Information

Proper Care

Cleaning

The entire Surfmaster PI Pro is waterproof and submersible. It can be cleaned with fresh water and a mild soap. After cleaning, dry the instrument thoroughly.

Weather Conditions

Protect your detector from excessively cold weather. Freezing can damage the electronic components, the case and/or the battery. Excessive heat can also damage the instrument. Never leave it in the sun. It's best to lay it in the shade when not in use. If it's left in a car or boat on a hot day, cover it to protect it from the direct rays of the sun, and then leave the windows slightly open to permit ventilation.

Saltwater

Saltwater is very corrosive! After your detector has been exposed to saltwater, rinse the loop and rods in fresh water. Then wipe it with a cloth dampened with fresh water, and dry it thoroughly.

Storage

If you plan to store your instrument for any length of time, unsnap the batteries and remove from the instrument. Whenever your instrument is not in use, turn the ON/OFF GAIN Knob all the way to the left until it clicks off.

Travel

If traveling and expecting large variations in altitude, such as traveling through mountain passes, disengage control box latches to allow equalization of pressure.

Opening Control Box

When opening the control box, first make sure the instrument is dry. Water, if allowed to contact the circuit board, will damage it.

When opening the control box to replace the batteries, always make sure the "O" ring is free of dirt or sand, and is properly positioned before the case is closed. If this "O" ring shows any signs of wear, replace it before using this instrument in the water. This "O" ring, White's Part Number 527-0040 is a custom shape, and can be ordered from your White's Dealer or Service Center. Failure to maintain the "O" ring properly will result in extensive damage to the instrument, and will not be covered under warranty. Failure to maintain the "O" ring properly will result in extensive damage to the instrument, and will not be covered under warranty. If traveling abroad or using this model extensively, ordering additional "O" rings is highly advisable. Professionals typically replace the "O" ring once a year.

"O" RING

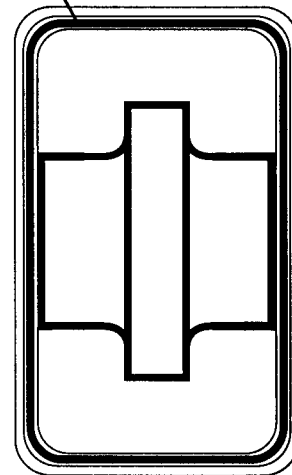

Service

White's reputation has been built on quality products backed by quality service. Our Factory Authorized Service Centers are factory trained and equipped. They offer the same quality service as the factory. Service before and after the sale is the cornerstone of our customer relations.

White's Authorized USA Service Centers:

Centerville Electronics
13810 B Braddock Road
Centerville, Virginia 20121
Toll Free 1-888-645-0202
Fax: 1-703-222-8625
E-Mail: centelec@vwx.com

Geoquest
106 US Hwy. 46
Saddle Brook, New Jersey 07662
Toll Free: 1-877-772-7443
Fax: 1-973-772-7773
E-Mail: geoquest@erols.com

Electronic Exploration
700 South Main
Lombard, Illinois 60148
Toll Free: 1-800-392-3223
Fax: 1-630-620-1005
E-Mail: tony@ee-il.com

White's Electronics, Inc.
1011 Pleasant Valley Road
Sweet Home, Oregon 97386
Telephone: 1-541-367-6121
Fax: 1-541-367-6629
E-Mail: nbaker@whiteselectronics.com

Before shipping detectors for service:

A. Contact your Dealer. There may be a quick, simple fix or explanation that will prevent having to send the detector in for service.

B. Double check the obvious, such as batteries, and try the detector in another area to be sure there is not interference.

C. Be sure to send all necessary parts with your detector, such as search-coil, batteries and holders, as these items can result in symptoms.

D. Always include a letter of explanation about your concerns, even if you have talked to the Service Center by telephone.

E. Take care in packaging instruments for shipping and always insure your package.

Warranty

If within two years (24 months) from the original date of purchase, your White's detector fails due to defects in either material or workmanship, White's will repair or replace at its option, all necessary parts without charge for parts or labor.

Simply return the complete detector to the Dealer where you purchased it, or to your nearest Authorized Service Center. The unit must be accompanied by a detailed explanation of the symptoms of the failure. You must provide proof of date-of-purchase before the unit is serviced.

This is a transferable manufacturer warranty, which covers the instrument two years from the original purchase date, regardless of the owner.

Items excluded from the warranty are non-rechargeable batteries, accessories that are not standard equipment, shipping / handling costs outside the continental USA, Special Delivery costs (Air Freight, Next Day, 2nd Day, Packaging Services, etc.) and all shipping / handling costs inside the continental USA 90 days after purchase.

White's registers your purchase only if the Sales Registration Card is filled out and returned to the factory address by your dealer, soon after original purchase for the purpose of recording this information, and keeping you up-to-date regarding White's ongoing research & development.

The warranty does not cover damage caused by accident, misuse, neglect, alterations, modifications, unauthorized service, or prolonged exposure to corrosive compounds, including salt.

Duration of any implied warranty (e.g., merchantability and fitness for a particular purpose) shall not be longer than the stated warranty. Neither the manufacturer or the retailer shall be liable for any incidental or consequential damages. Some states however, do not allow the limitation on the length of implied warranties, or the exclusion of incidental or consequential damages. Therefore, the above limitations may not apply to you.

In addition, the stated warranty gives you specific legal rights, and you may have other rights which vary from state-to-state.

The foregoing is the only warranty provided by White's as the manufacturer of your metal detector. Any "extended warranty" period beyond two years, which may be provided by a Dealer or other third party on your detector, may be without White's authority involvement and consent, and might not be honored by White's Electronics, Inc.

Warranty Transfer

If for any reason you should sell your Surf P.I. Pro prior to the date the warranty expires, the remaining warranty is transferable. **This transfer is authorized by calling 1-800-547-6911, and getting an Authorization Number.**

Simply fill out the following information, including the Authorization Number, seal it in a stamped envelope, and send it to **White's Electronics, 1011 Pleasant Valley Road, Sweet Home, Oregon 97386.** The remaining warranty period will then be available to the new owner.

The Warranty Statement applies to both the original owner as well as the second owner.

 **WARRANTY TRANSFER**

Original Owner:

Name: _____
Address (Which appears on the original warranty card):

Instrument Serial Number: _____
Original Purchase Date: _____

New Owner:

Name: _____
Address: _____

Comments: _____

Distributor Authorization Code: _____

Video

A Video cassette detailing the proper use of the Surfmaster P.I. Pro is available. This video explains how to use the Surfmaster P.I. Pro in the field, as well as explaining the many varied options. Intended for English speaking persons, it is recorded on VHS format.

White's recommends this video cassette as a valuable learning aid for both beginners, and experienced metal detector users. For more information, please contact your Dealer.

Owner Information

Serial Number: _____ (*inside of battery compartment*)

Purchase Date: _____ (*The date on the sales receipt*)

Dealer Name: _____

Address: _____

Telephone #: _____

Payment method: _____

Personal markings: _____
