

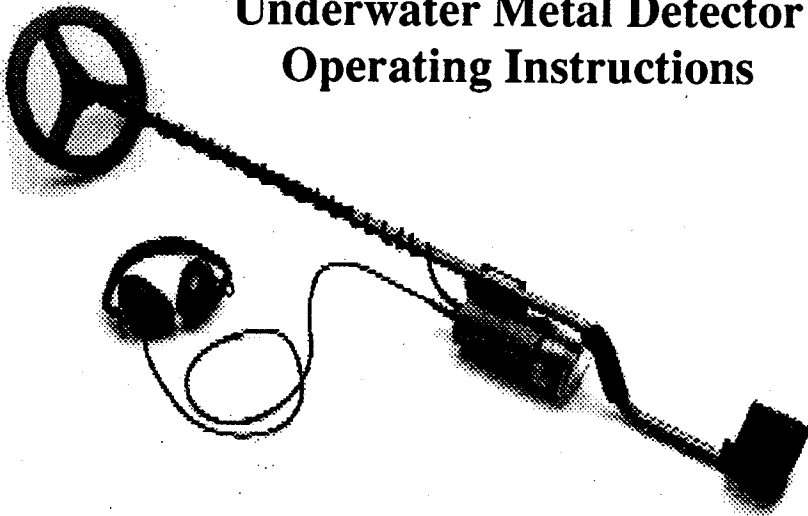

Treasuremaster PI 3000

Underwater Metal Detector Operating Instructions



 **electronics, inc.**



Index

Assembly	2-5
Batteries	6-7
Tuning Instructions	8-9
Explanation of Control Positions	10-13
Off	10
Battery Check	10-11
AUTO (Automatic)	11-12
PP (Pinpoint)	12-13
Search Methods	14-15
Detection	14
Digging	14
Mineralization	14-15
Securing the Detector	15
Advanced Techniques	16-17
Care of Your Detector	18-20
Warranty	21



Assembly

Remove all parts from the shipping carton.
(See Pages 4 and 5)

Place rubber washers on loop isolator, then slide onto loop. Attach with nylon bolt and nut provided.

Attach the signal hole end of the adjustable rod to the loop isolator by lining up the hole in the rod with the button on the loop isolator.

Insert the double button spring clip into the other end of the adjustable rod so that the buttons line up with and show through the two attachment holes.

Insert the adjustable rod into the handle "S" rod lining up the spring clip buttons with the desired adjustment holes on the "S" rod.

Attach and adjust the arm cup (elbow support) with the steel bolt provided. Note that three different positions are available.

With the control box and headphones together, loop cable and headphone cable separated, wind the loop cable around the rod starting as the cable exits the loop. First revolution over the top of the rod. Note that handheld assembly requires extensive cable winding around the rod and hipmount assembly requires only moderate cable winding around the rod.

Assembly continued....

For handheld assembly, compress the desired buttons on the rod and attach control box. Note this procedure is eased by compressing the buttons on one side aligning the control box bracket then compressing the buttons on the other side and sliding the bracket into place. Disassembly is also eased by releasing one side and twisting the bracket off the rod. Note that there are several different attachment positions available on the "S" rod. Select one based on personal preference.

For hipmount assembly, place the pouch on the control box so that the control switch is exposed through the slot. Weave the belt through the available belt loops on the pouch.

See section on batteries to continue.

Assembly continued.....

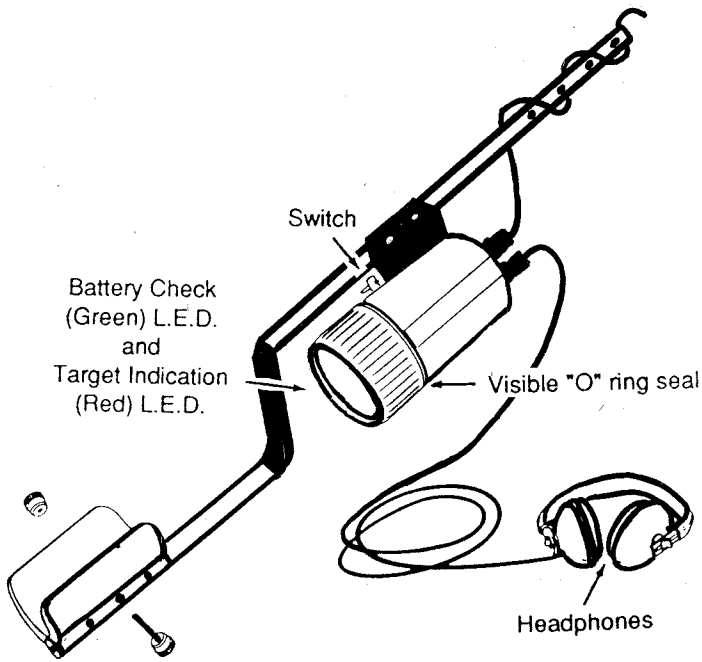
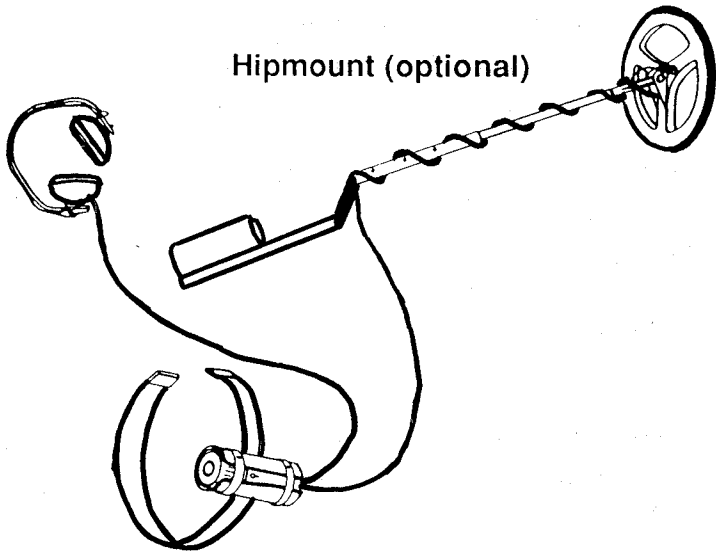

Assembly continued....

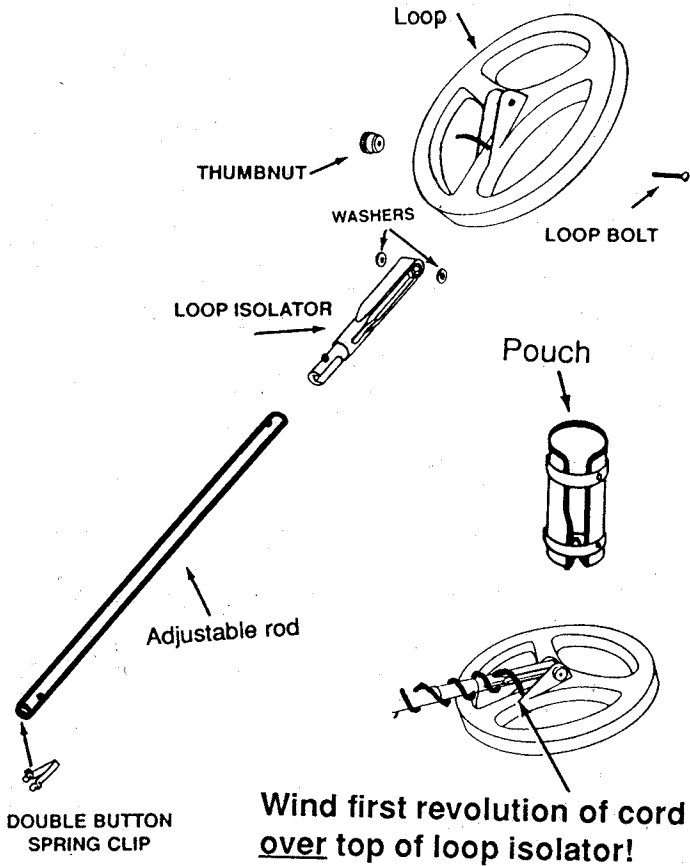



Batteries

Install the batteries into the battery holder as shown:

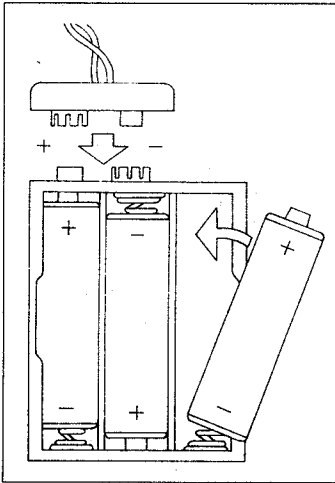

Battery Installation:

Place flat end or bottom of battery against battery holder spring. Then push top of battery down and into place.

Unscrew the clear section of the control housing and attach the battery pack to the battery lead. Position the battery pack on the side of the circuit board opposite the red and green LED lights.

Make sure "O" ring is in place, free of dirt and sand, and well greased.

Screw clear control housing cover onto control housing securely.

Six Alkaline AA batteries are ideal for use with this unit and should provide approximately eight hours of

Batteries continued.....

use. Battery life will vary significantly with temperature, the number of targets detected, and the type of battery used.

An optional rechargeable battery #512-0014 (6 cell) nicad, and charger #509-0016 can be purchased as an accessory.



Tuning Instructions

- 1) Assemble PI 3000 as shown under *Assembly*. This instrument may be used as a handheld or hipmount based on your personal preference. Optional control box mounting positions are available on the handheld rod assembly.
- 2) Remove the clear plastic cover of the control box by rotating it counterclockwise.
- 3) Connect the battery lead to the battery pack and replace the clear cover, rotating it clockwise until it is firmly secure.
- 4) Set the adjustable rod to the length you find most convenient to use and wind excess cable around rod as shown under *Assembly*.
- 5) Place the headphones on your head assuring that the cable is neither tangled nor in your way.
- 6) Place the loop flat on the ground or sand as it will be during normal searching and rotate the switch located on the control box slowly in the clockwise direction.
- 7) The first position tests battery strength. You should see a green light through the clear cover of the control box, if not, replace the batteries.
- 8) The second position AUTO continuously tunes for the salt/mineralization of the area. It is the primary search

Tuning Instructions continued.....

mode of the PI 3000. The loop must be in continuous motion (moving from side to side) for this mode to operate properly.

9) You should hear a slight background hum or threshold.

10) Sweep the loop smoothly and evenly from side to side slightly overlapping each pass.

11) An increase in the background or threshold tone, and a red light glowing inside the clear cover indicates a metal target.

12) To pinpoint a target's precise location, "X" the loop over the target. The loudest sound indicates target center. If the target still seems large, "X" the target with the loop held slightly higher from the ground/sand.

13) The third position PP (Pinpoint) can optionally be used for pinpointing a metal's exact location. The loop doesn't have to be in motion for the PP mode to respond to metal. After PP is used, switch back to AUTO for general searching.

14) For more information, please read the following explanations.



Explanation of Control Positions

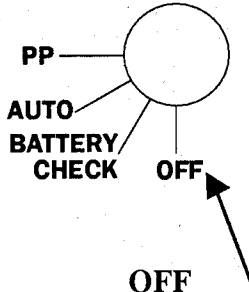

Both LED's off. Unit turned off.

- 1) The Off position, control fully counterclockwise, when the PI 3000 is not in use.
 - a) It is advisable to disconnect and remove the batteries from the instrument during storage.
 - b) Store instrument in a cool dry place with clear plastic case cover loose.
 - c) Make sure control is in Off position when not in use.

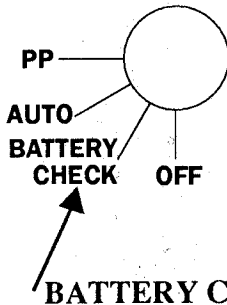

Red LED will flash. Green LED will illuminate if batteries are in good condition.

Explanation of Control Positions continued...

- 2) The second position tests the battery strength.
 - a) The Red LED light will flash momentarily then fade.
 - b) The Green LED light should continue to shine brightly if the batteries are good.
 - c) If the Green LED light doesn't shine, replace batteries.

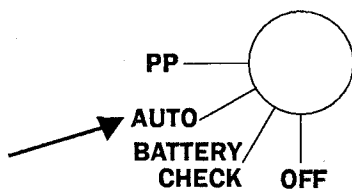

AUTO

In this position the detector will automatically retune so that the audio is at a level which lets the detector operate at its maximum sensitivity. AUTO is the PI 3000's main search mode.

- 3) The third position AUTO is used as follows:
 - a) When the loop is held flat on the ground/sand, the AUTO position compensates for mineralization and/or salt content of the area to be searched.
 - b) Switch to AUTO position with loop on ground. Tuning is virtually instantaneous. Retuning is continuous in the AUTO position.
 - c) Most areas are very inconsistent in the content of mineralization/salt. For such areas, just leave the control in the AUTO position and search as normal. The loop must always be in motion when searching

Explanation of Control Positions continued...

in this manner. A slow sweep from side to side will ensure that no targets will be tuned out.

d) The AUTO position may also be used to aid pinpointing. Once a target is detected, Slowly "X" target several times. Loudest volume indicates target center. If pinpointing is difficult, lift the loop slightly higher above the target and again "X".

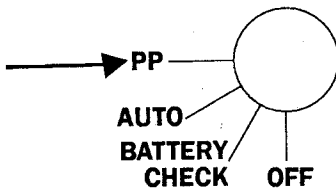

PP (PINPOINT)

- 4) The fourth and final position is pinpoint.
 - a) Increases in the threshold in most cases indicate a metal target. "X" the loop over the target to determine its center (pinpoint). The loudest volume indicates target center. If the center isn't obvious raise the loop slightly higher and again "X" the target listening for the loudest volume. The loop doesn't have to be in motion while in the PP position.
 - b) Decreases or increases in threshold that seem to blanket the ground/sand continuously indicate changing mineralization. If decrease or increase persists, switch back to the AUTO position holding the loop flat on the ground and use the AUTO position for pinpointing.

Explanation of Control Positions continued...

c) On some occasions when the mineralization and salt are extremely consistent (unchanging), the PP position can be used as an operating or search mode. The PI 3000 is susceptible to changes in minerals/salt in the PP position and these changes will be indicated by decreases or increases in threshold that are not isolated to a small area. Occasionally, switching back to AUTO will correct for such changes. If, however, such changes persist, switch back to AUTO and use AUTO for searching the area.



Searching

1) Detection

- a) The PI 3000 is designed to respond to all types of metals which includes, but not limited to, iron, tin, aluminum, lead, zinc, copper, nickel, silver, gold, platinum, and their alloys.
- b) The PI 3000 will not detect non-metallic substances such as uranium, diamonds or other such gem stones.
- c) Depth of detection will vary with the type of metal, its alloy, size, shape, and how long its been in the ground which causes a chemical reaction (halo effect) between it and the surrounding soil.
- d) The PI 3000 is designed to respond to coin size and larger targets.

2) Digging

- a) Underwater it is advisable to wear extra weights, as the easiest method of digging is to use a rapid fanning motion with your hand to remove sand and silt.
- b) Shallow water and beach digging is best completed with a sand scoop which acts like a sieve to separate the sand and silt from the target. Check with your dealer regarding sand scoops.
- c) There are many digging tools available from your dealer made for rocky hard ground or clay.

3) Mineralization

- a) If when searching an area your instrument detects one particular rock, we would suggest you

Searching continued.....

examine it carefully as it could have a valuable ring or coin encrusted inside or be a valuable meteorite.

b) If your instrument detects many rocks in an area you are searching, the rocks probably have a very high mineral content, either:

- 1) Sweep the loop slightly higher.
- 2) Switch to AUTO with the loop held over one of these rocks then switch to PP to lock the compensation of the rock mineral in continuously, and use PP to search the area.
- 3) Switch to AUTO and leave the control in that position.

4) Securing the Detector

a) The PI 3000 is slightly buoyant, so it is advisable to secure the detector with a lanyard (small rope) to the diver, so that the diver can leave his hands free for digging targets.



Advanced Techniques

1) A nail or length of wire will sometimes produce a double or single reading, depending upon whether the loop is passed across it lengthwise or across its width. Therefore, it is worthwhile to sweep targets from several directions. Coins will always produce one reading, regardless of sweep direction.

2) Whether working the surf, an old swim hole on a river, or any other body of water, it is important to consider the incredibly powerful force the water action has over the sand, silt, gravel and valuables.

a) Many of the characteristics that apply to prospecting for natural gold apply to beach and surf hunting as well.

b) As an example, rings and coins are heavier than sand. The tide washing back and forth over the beach acts like a big gold pan circulating the sand and accumulating the heavier material together.

c) The results of this action is a narrow band of coins and rings at a certain spot in the surf. The trouble is this band is constantly changing.

d) Experienced operators will attempt to locate this band and once several rings or coins are located will continue searching parallel to the shore in order to take advantage of the water sluicing action.

e) As the water circulates the sand, coins and rings often become trapped by natural obstructions like logs, boulders and other material. Just like gold gets trapped behind boulders and rock formations in a river. Check around all visible obstructions.

Advanced Techniques continued.....

f) After a big storm is the best time to search the ocean beaches, as much sand has circulated and many rings and coins that were previously too deep come near the surface.



Care of Your Detector

- 1) Like all diving equipment, the detector should be rinsed with freshwater after use in saltwater. (**Saltwater is very corrosive.**)

- 2) Whenever removing the clear plastic cover to change the batteries make sure the "O" ring is free of dirt, sand, etc., and that it is covered with a light coating of silicon grease.
 - a) Recoat "O" ring with silicon grease often.
 - b) Inspect "O" ring and replace it if damaged.

- 3) Protect your instrument from extreme temperatures.
 - a) If left in the car on a hot day, cover it to protect it from prolonged exposure to direct sunlight and crack the window slightly.
 - b) Avoid prolonged exposure to sub-zero temperatures.

- 4) Make sure the instrument is OFF when not in use.

- 5) During periods of prolonged storage, remove the batteries and leave the clear plastic cover loose. Store in a cool, dry place.

- 6) If traveling and expecting large variations in altitude such as on an airplane or traveling through mountain passes, make sure clear plastic cover is loose to allow equalization of pressure.

Care of your Detector continued.....

7) SELICA GEL BAG - The detector contains a silica gel bag to protect the circuit from moisture which may enter the instrument through condensation or when changing the batteries.

a) Periodically dry out this bag in a warm oven in which the maximum temperature must not exceed 120 C or 248 F.

b) This bag is located in the battery compartment, behind the first foam pad.

8) Do not tighten the black fittings on the loop and between the loop/headphone cable and control box. These fittings are adjusted at the factory for maximum water seal, and have been pressure tested before leaving the factory. Over tightening will cause leakage.

9) If the worst happens and your control box fills with saltwater, the following steps will avoid further problems.

a) Immediately disconnect and remove the battery pack, all foam layers, and silica gel bag.

b) Flush the inside of your control box, including the circuit board repeatedly with fresh tap water to remove all traces of saltwater.

c) Rinse the foam layers and gel bag, and allow to dry.

d) Remove the batteries from the battery pack and rinse the pack. Discard the batteries.

e) Allow all components to completely dry.

f) Inspect the "O" ring to see if it was the cause of the leak, if so, replace and regrease.

Care of your Detector continued.....

- g) Reassemble the instrument with new batteries. Often it will work fine.
- h) If no obvious reason is found for the leak or if the unit is not operating, at this point, return the instrument for servicing.
- i) These steps will avoid extensive saltwater corrosion. Extensive saltwater corrosion is considered neglect and is not covered by the warranty.

Treasure Hunter Code of Ethics



- 1) *Respect the rights and property of others.*
- 2) *Observe all laws.*
- 3) *Aid law enforcement officials whenever possible.*
- 4) *Never destroy historical or archeological treasures.*
- 5) *Leave the land and vegetation as it was.*
- 6) *Remove all trash and litter when you leave.*
- 7) *All treasure hunters may be judged by the example you set.
Always conduct yourself with courtesy and consideration.*

White's Electronics, Inc.
1011 Pleasant Valley Road
Sweet Home, OR 97386
Distribution: 1-800-547-6911
Factory: 1-541-367-6121
FAX: 1-541-367-2968
E-Mail: whites@halcyon.com